



Silicon Hill

---

## Úvod do síťových technologií

# Osnova – Co vás čeká

- Fyzická vrstva – Média
- Síťové vrstvy a zapouzdření
- MAC Adresa
- IP Adresa, síť a masky
- Příklady komunikace
- Přehled síťových prvků (HW)
- Diskuze

# Fyzická vrstva

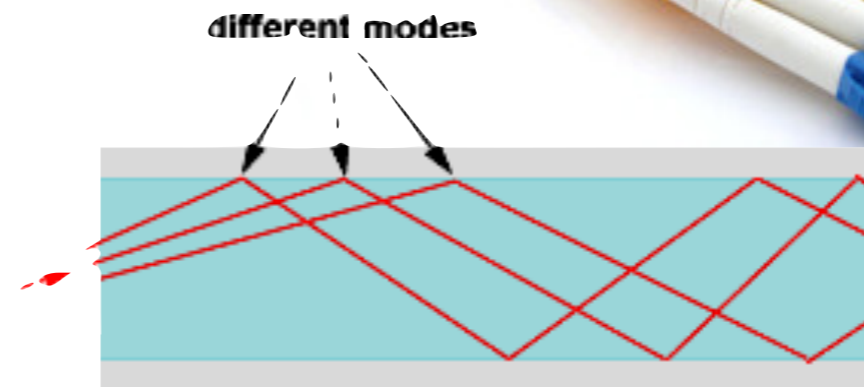
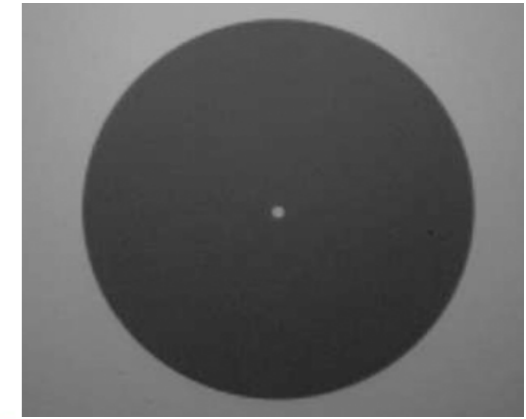

Multimode Fiber



Single Mode Fiber

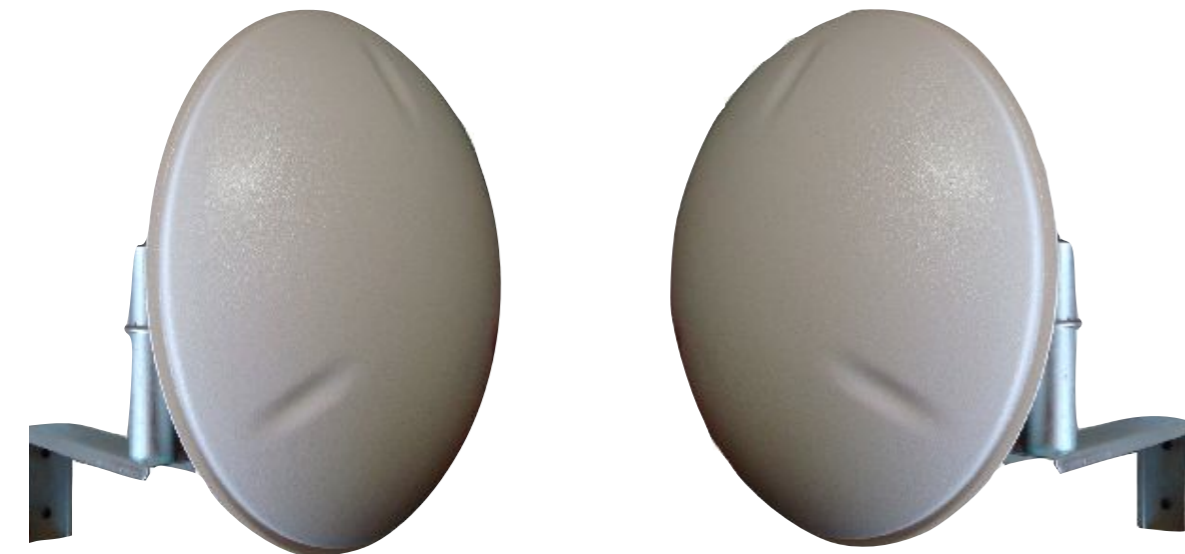
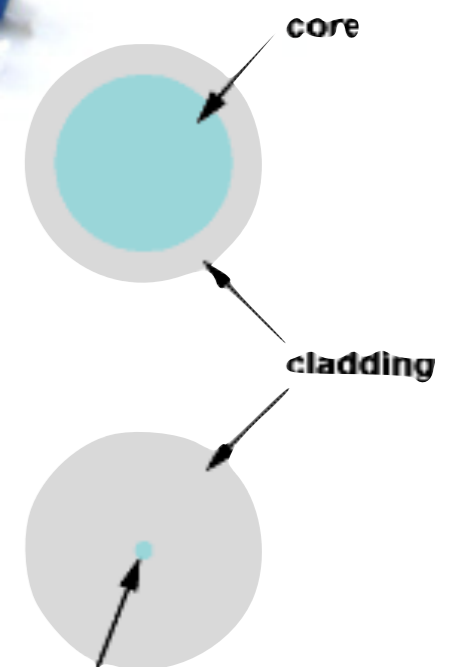

# Přímý / Křížený kabel

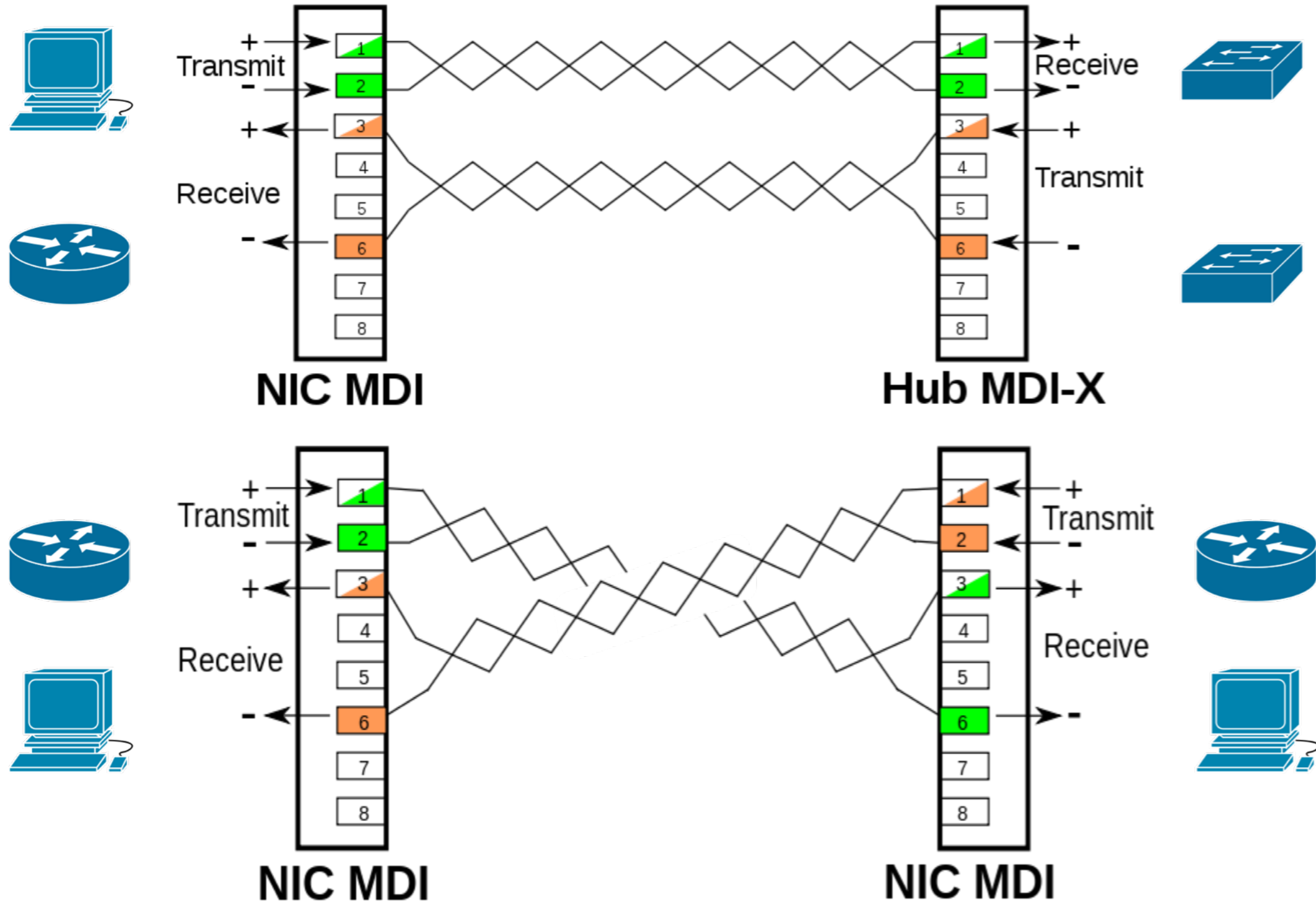

# Síťové vrstvy

#	ISO/OSI	TCP/IP	Jednotka	
7	Application			
6	Presentation	Application	Data	HTTP, FTP, RTP, ...
5	Session			
4	Transport	Transport	Segment	TCP, UDP
3	Network	Network	Packet	IP, IPv6
2	Data link	Data link	Frame	Ethernet, ATM (xDSL)
1	Physical	Physical	Bit	Metalika, Optika, Bezdrát

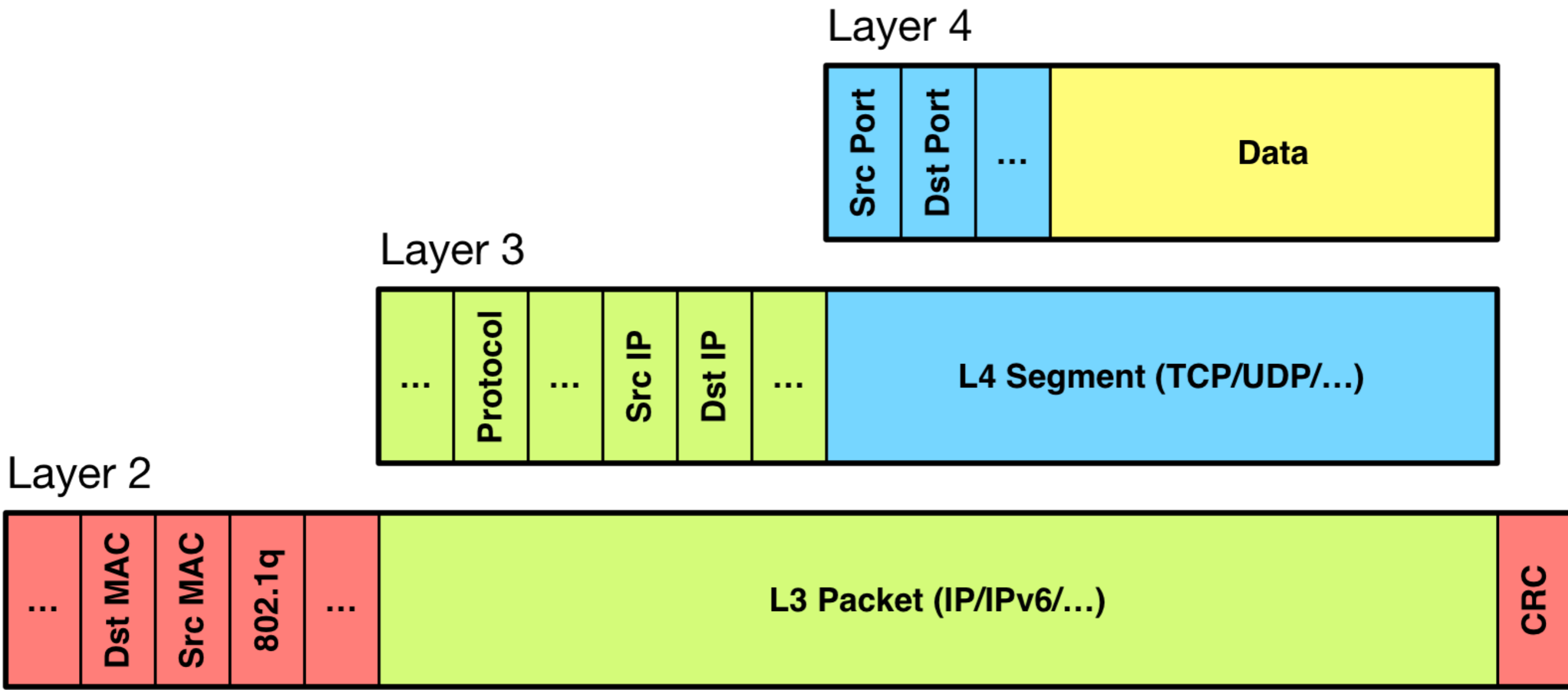

# MAC Adresy (L2, 6B)

- 00:23:32:ed:d5:15, 0023.32ed.d515

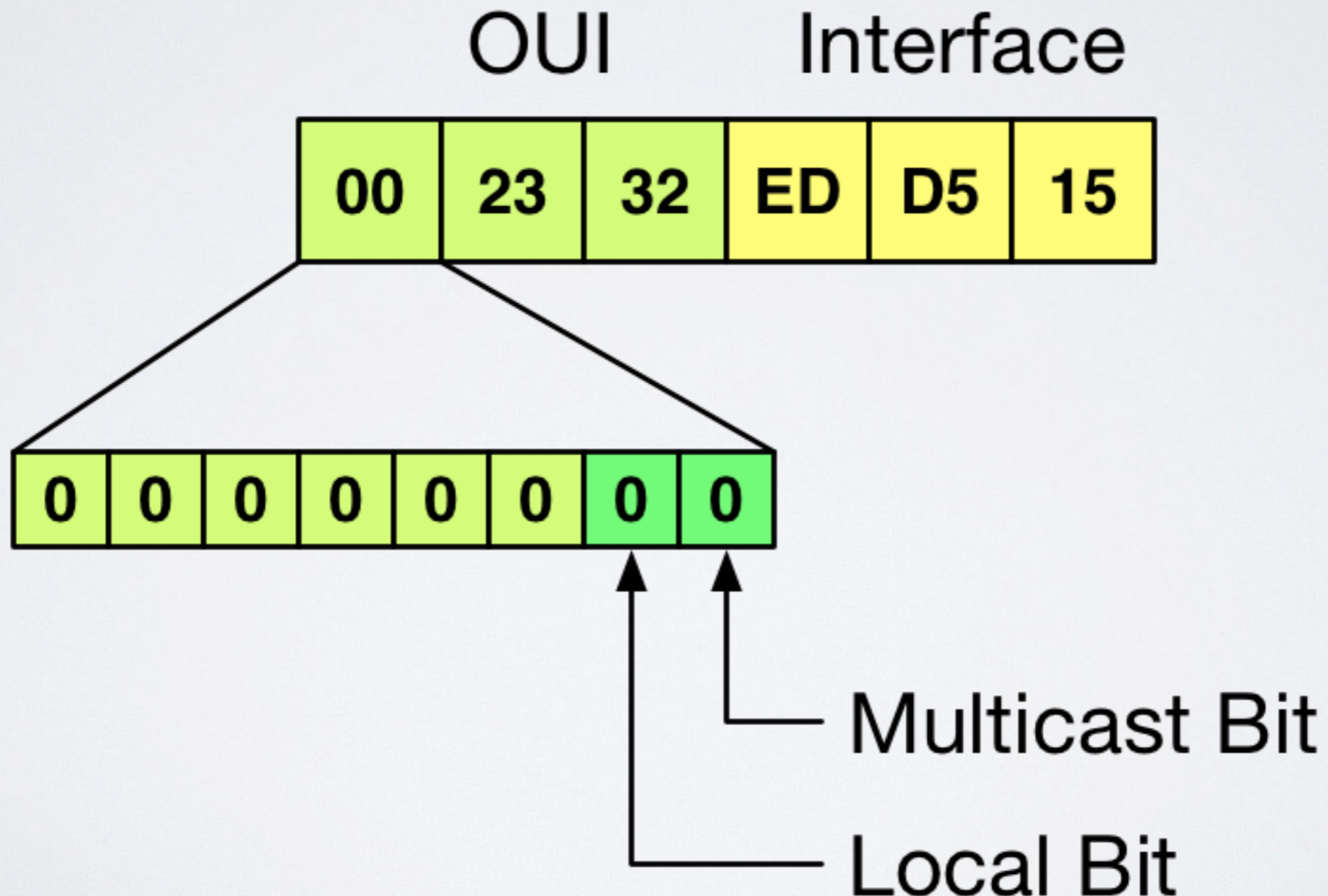

# IPv4 Adresy (L3, 4B)

- Zapisováno dekadicky po bytech
  - 147.32.127.214
  - 192.168.15.0
- Privátní adresy (RFC1918)
  - 192.168.0.0/16
  - 172.16.0.0/12
  - 10.0.0.0/8



# IP Adresy a sítě

- Síť může být zapsána jako
  - 147.32.114.0/24
  - 147.32.114.0 netmask 255.255.255.0
- 255.255.255.0 =  
11111111 11111111 11111111 00000000
- /24 = Počet 1 zleva, zbytek 0

# Příklad 1

- Je adresa 192.168.10.10 ze sítě 147.32.127.128/25 ?

/25 = 255.255.255.128 (Maska sítě)

11111111 11111111 11111111 10000000

192.168.10.10 =

11000000 10101000 00001010 00001010

147.32.127.128 =

10010011 00100000 01111111 10000000

# Příklad 1

- Je adresa 192.168.10.10 ze sítě 147.32.127.128/25 ?

/25 = 255.255.255.128 (Maska sítě)

11111111 11111111 11111111 10000000

192.168.10.10 =

11000000 10101000 00001010 00001010

147.32.127.128 =

10010011 00100000 01111111 10000000

- **Ne**, adresy sítí se neshodují

# Příklad 2

- Je adresa 192.168.10.10 ze sítě 192.168.10.0/24 ?

/24 = 255.255.255.0 (Maska sítě)

11111111 11111111 11111111 00000000

192.168.10.10 =

11000000 10101000 00001010 00001010

192.168.10.0 =

11000000 10101000 00001010 00000000

# Příklad 2

- Je adresa 192.168.10.10 ze sítě 192.168.10.0/24 ?

/24 = 255.255.255.0 (Maska sítě)

11111111 11111111 11111111 00000000

192.168.10.10 =

11000000 10101000 00001010 00001010

192.168.10.0 =

11000000 10101000 00001010 00000000

- **Ano**, adresy sítí se shodují

# Typické masky

- /32 – 255.255.255.255 – 1 adresa
- /30 – 255.255.255.252 – 2 adresy = “Spojovačka”
- /25 – 255.255.255.128 – 126 adres = “Půl céčka”
- /24 – 255.255.255.0 – 254 adres = “Céčko”
- /22 – 255.255.252.0 – 1022 adres
- /16 – 255.255.0.0 – 65534 adres = “Béčko”
- /8 – 255.0.0.0 – 16777214 adres = “Áčko”

# ipcalc – Síť snadno

```
$ ipcalc 147.32.127.214/25
```

```
Address: 147.32.127.214      10010011 00100000 01111111 1 1010110  
Netmask: 255.255.255.128 = 25 11111111 11111111 11111111 1 0000000  
Wildcard: 0.0.0.127        00000000 00000000 00000000 0 1111111
```

```
=>
```

```
Network: 147.32.127.128/25  10010011 00100000 01111111 1 0000000  
HostMin: 147.32.127.129    10010011 00100000 01111111 1 0000001  
HostMax: 147.32.127.254    10010011 00100000 01111111 1 1111110  
Broadcast: 147.32.127.255  10010011 00100000 01111111 1 1111111  
Hosts/Net: 126              Class B
```

- <http://jodies.de/ipcalc>
- `brew install ipcalc`
- `aptitude install ipcalc`

# VLSM + Subnet zero

192.168.0.0/24 0 ... 255	192.168.0.0/25 0 ... 127	192.168.0.0/26 0 ... 63	192.168.0.0/27 0 ... 31	192.168.0.0/28 0 ... 15	192.168.0.0/29 0 ... 7	192.168.0.0/30 0, 1, 2, 3
						192.168.0.4/30 4, 5, 6, 7
						192.168.0.8/30 8, 9, 10, 11
					192.168.0.8/29 8 ... 15	192.168.0.12/30 12, 13, 14, 15
						192.168.0.16/30 16, 17, 18, 19
						192.168.0.20/30 20, 21, 22, 23
	192.168.0.16/28 16 ... 31					192.168.0.24/30 24, 25, 26, 27
					192.168.0.16/29 16 ... 23	192.168.0.28/30 28, 29, 30, 31



# Domácí síť

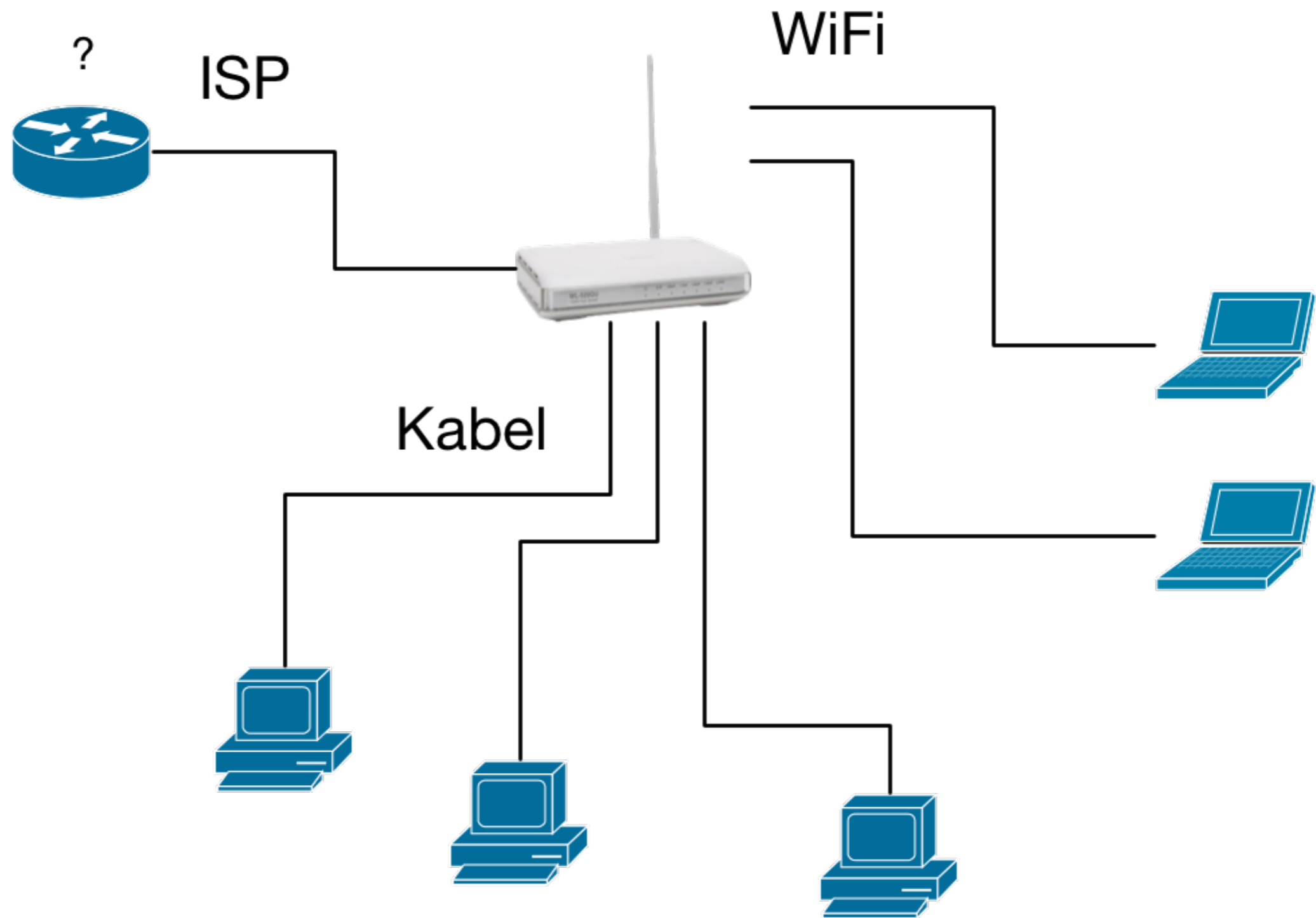

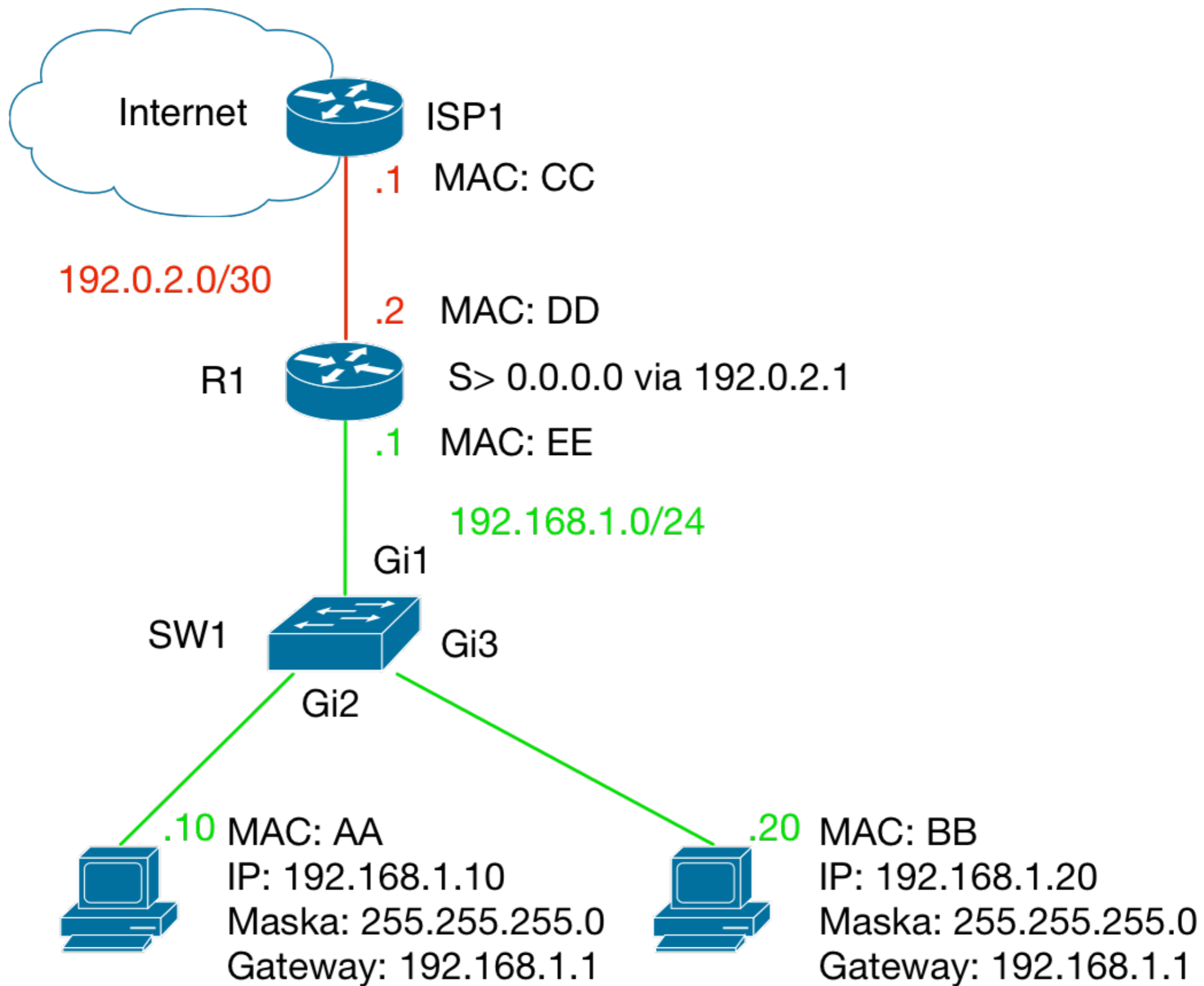

# Komunikace na L2

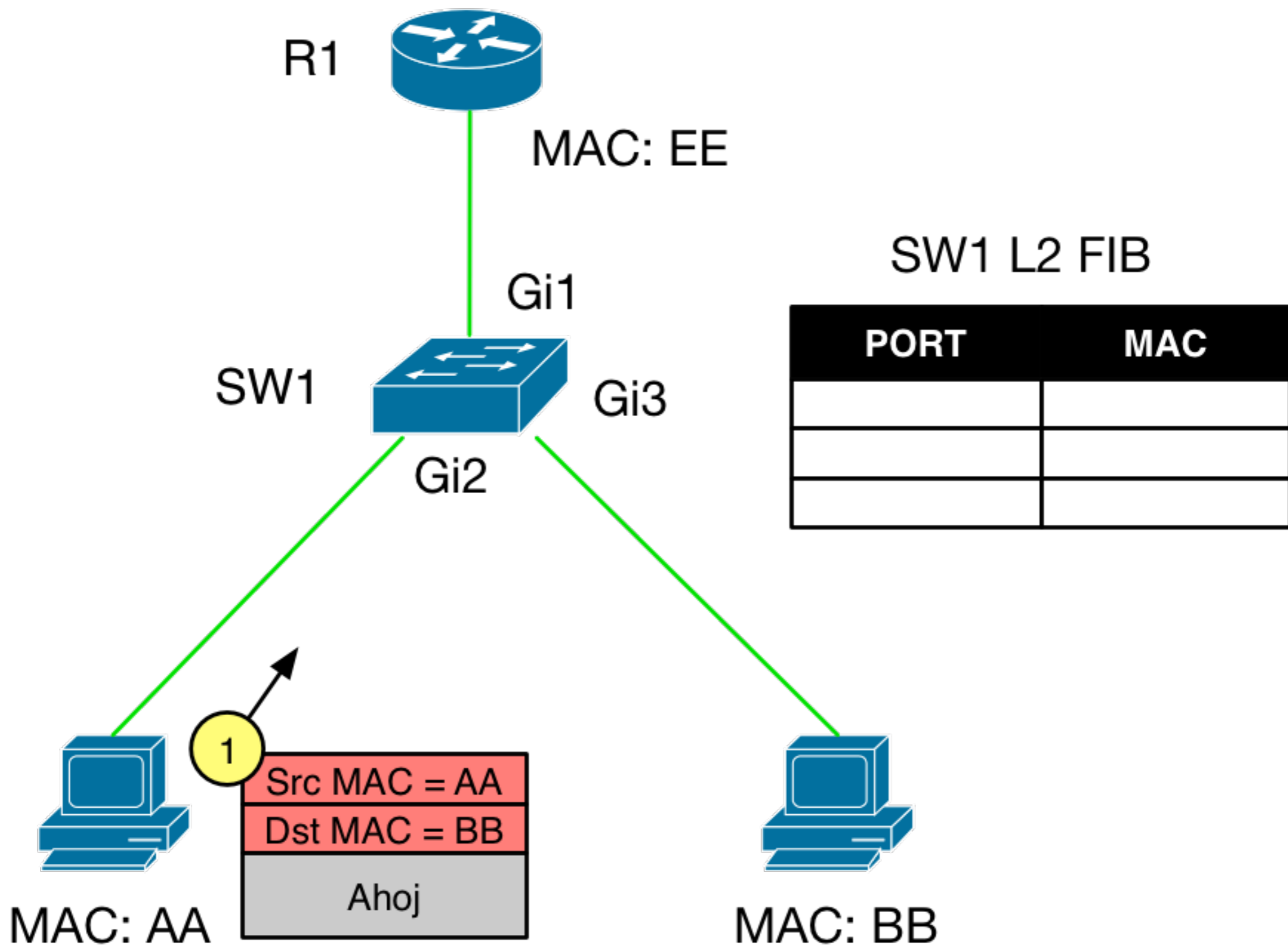

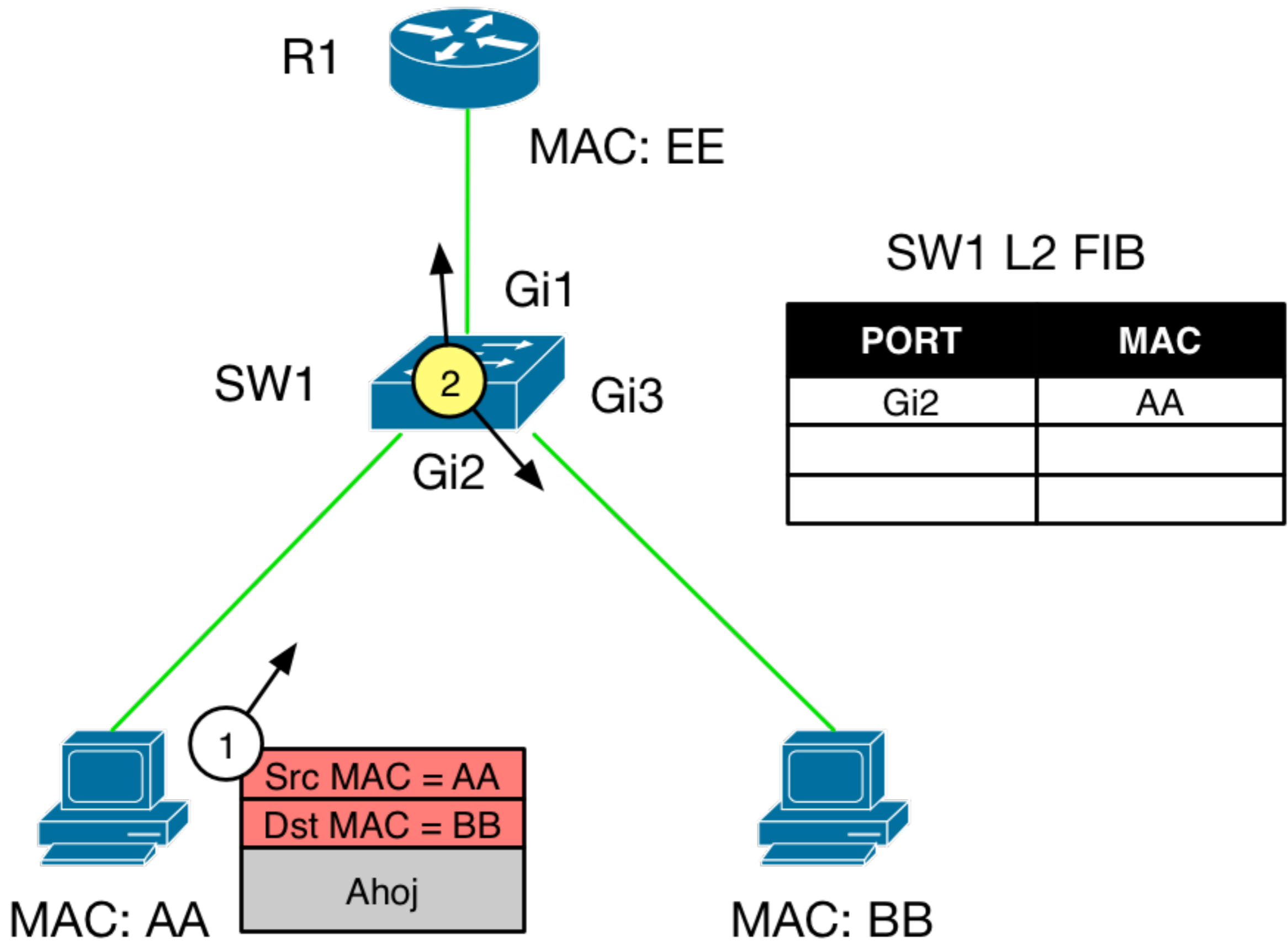

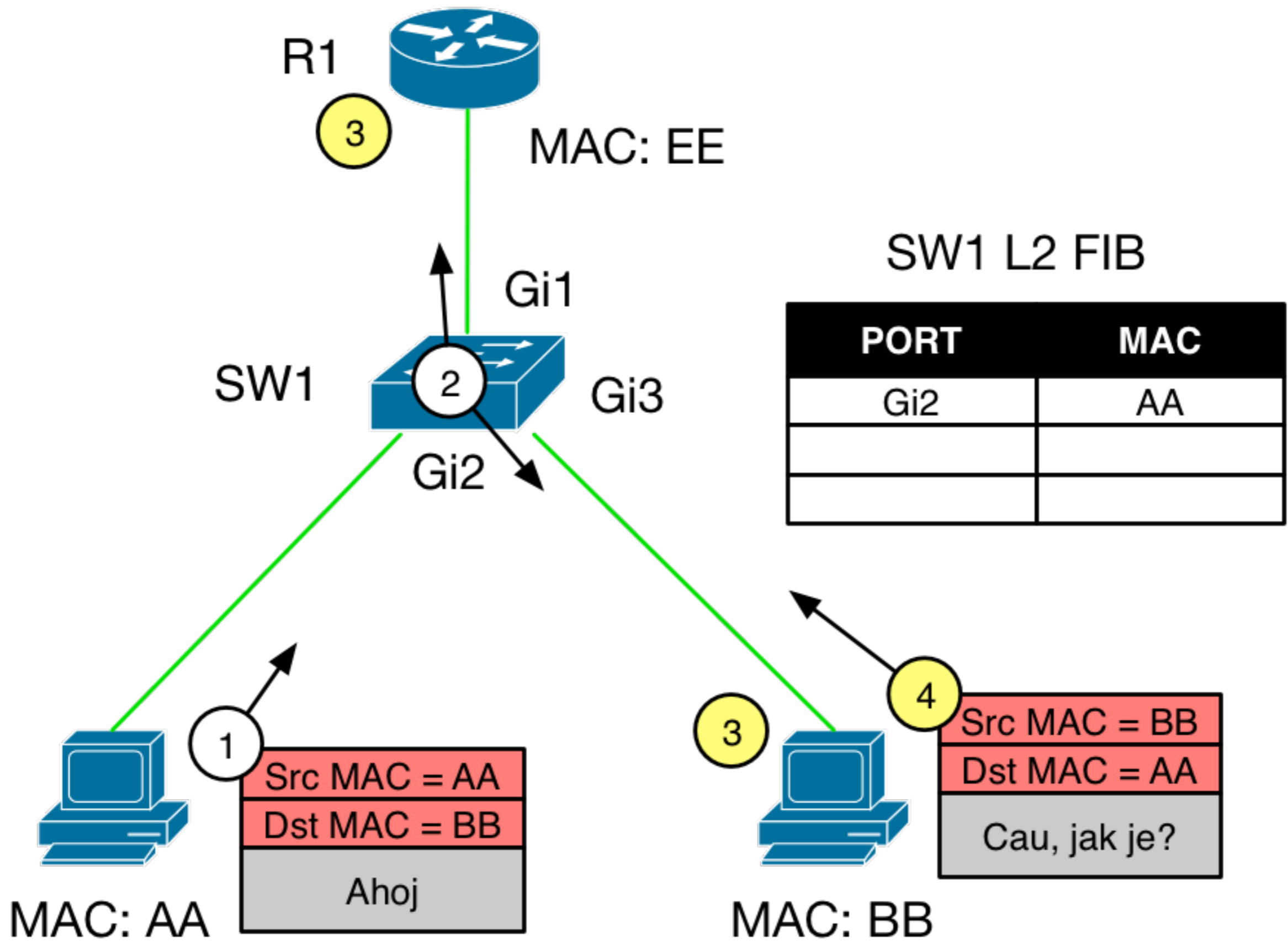

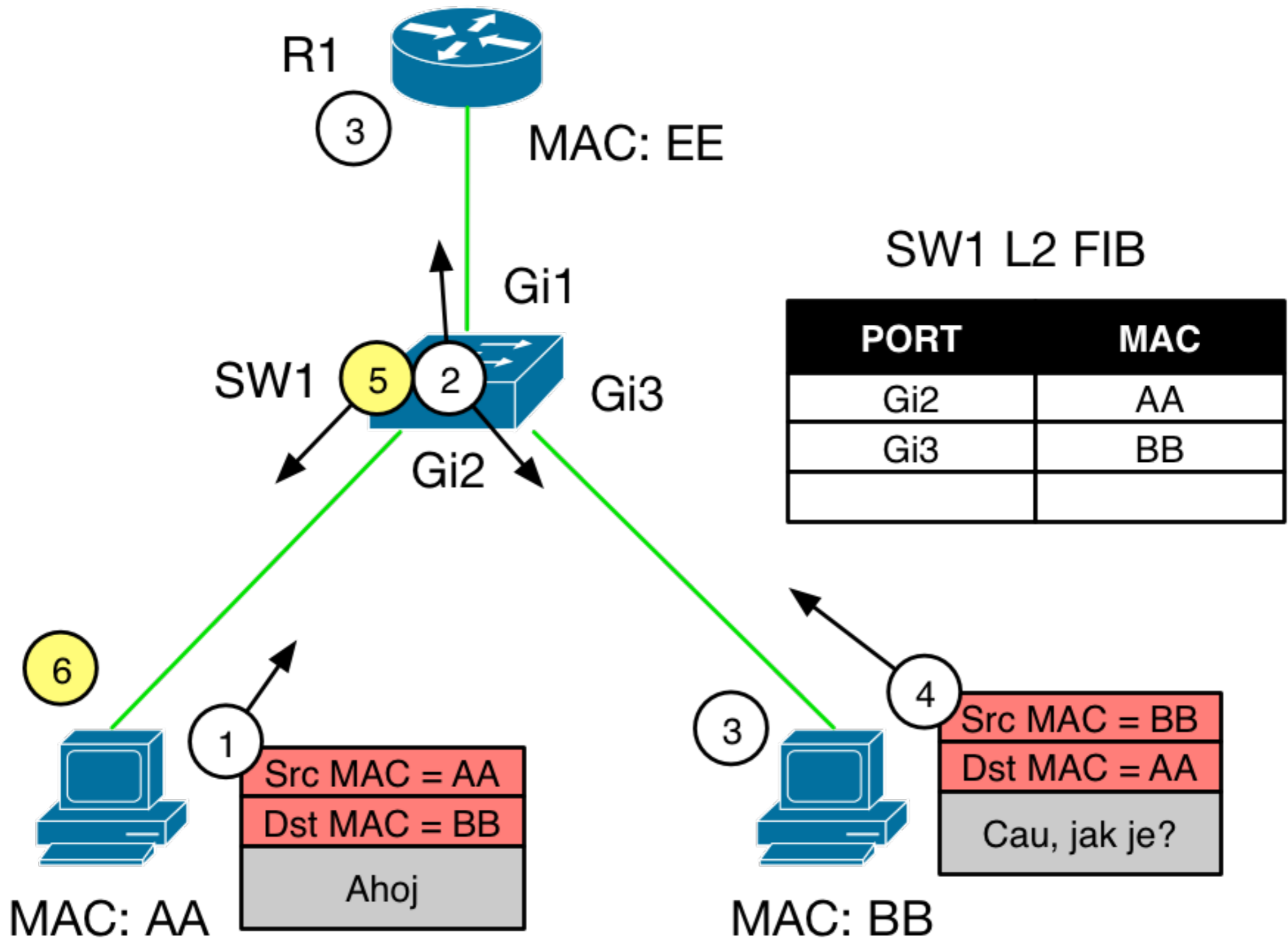

# ARP

Address Resolution Protocol



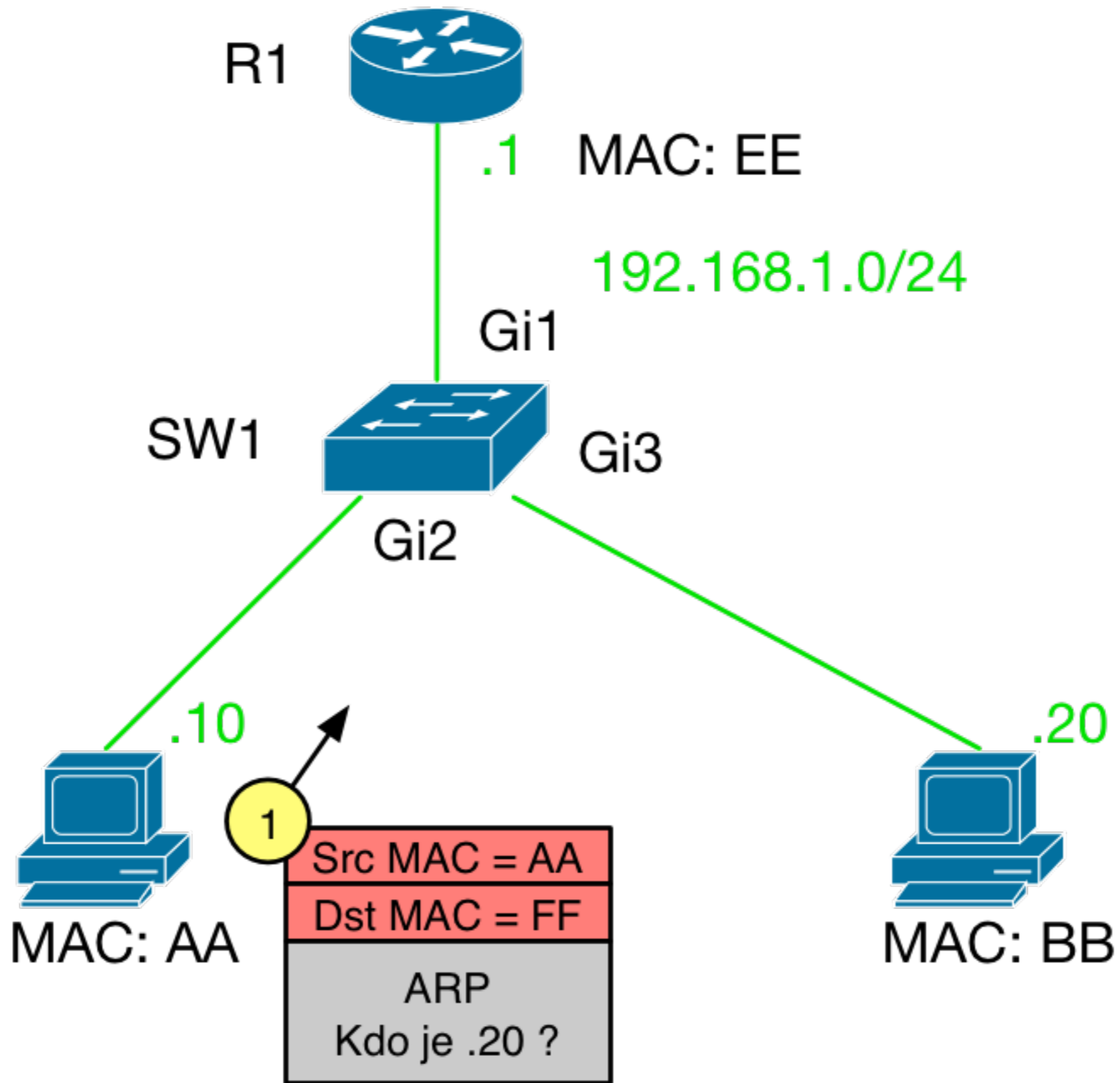

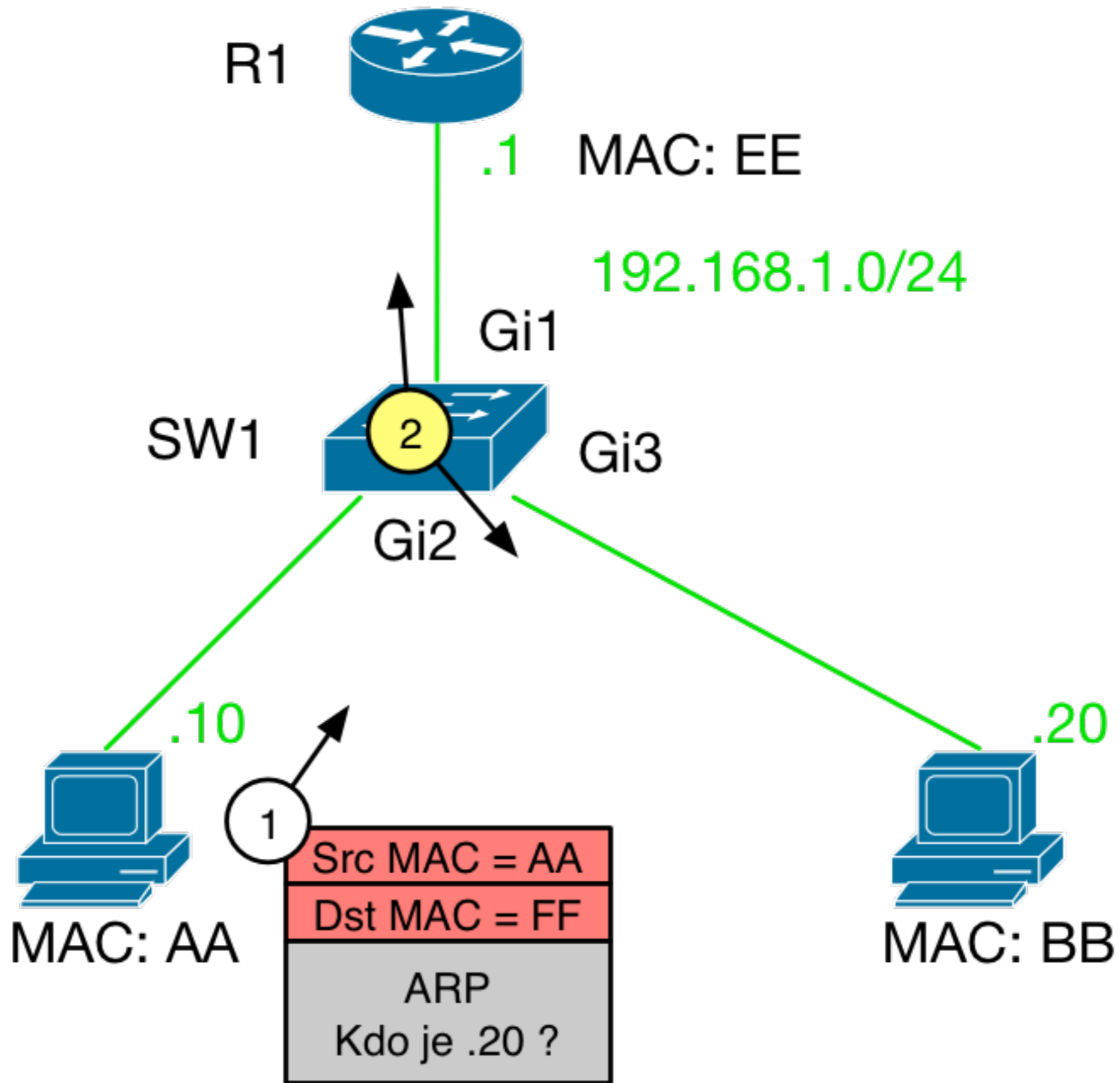

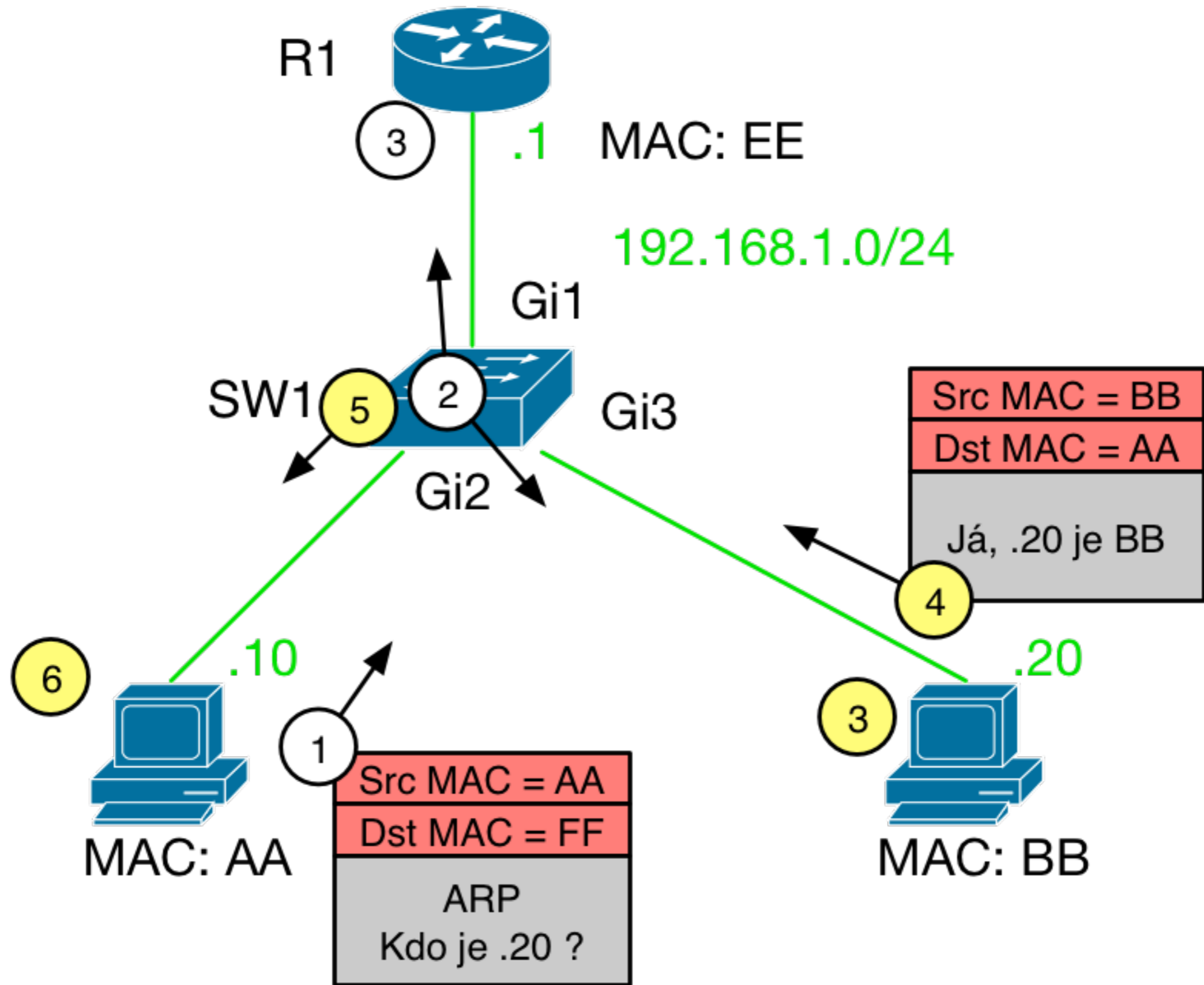

# Komunikace na L3 I.

Local network

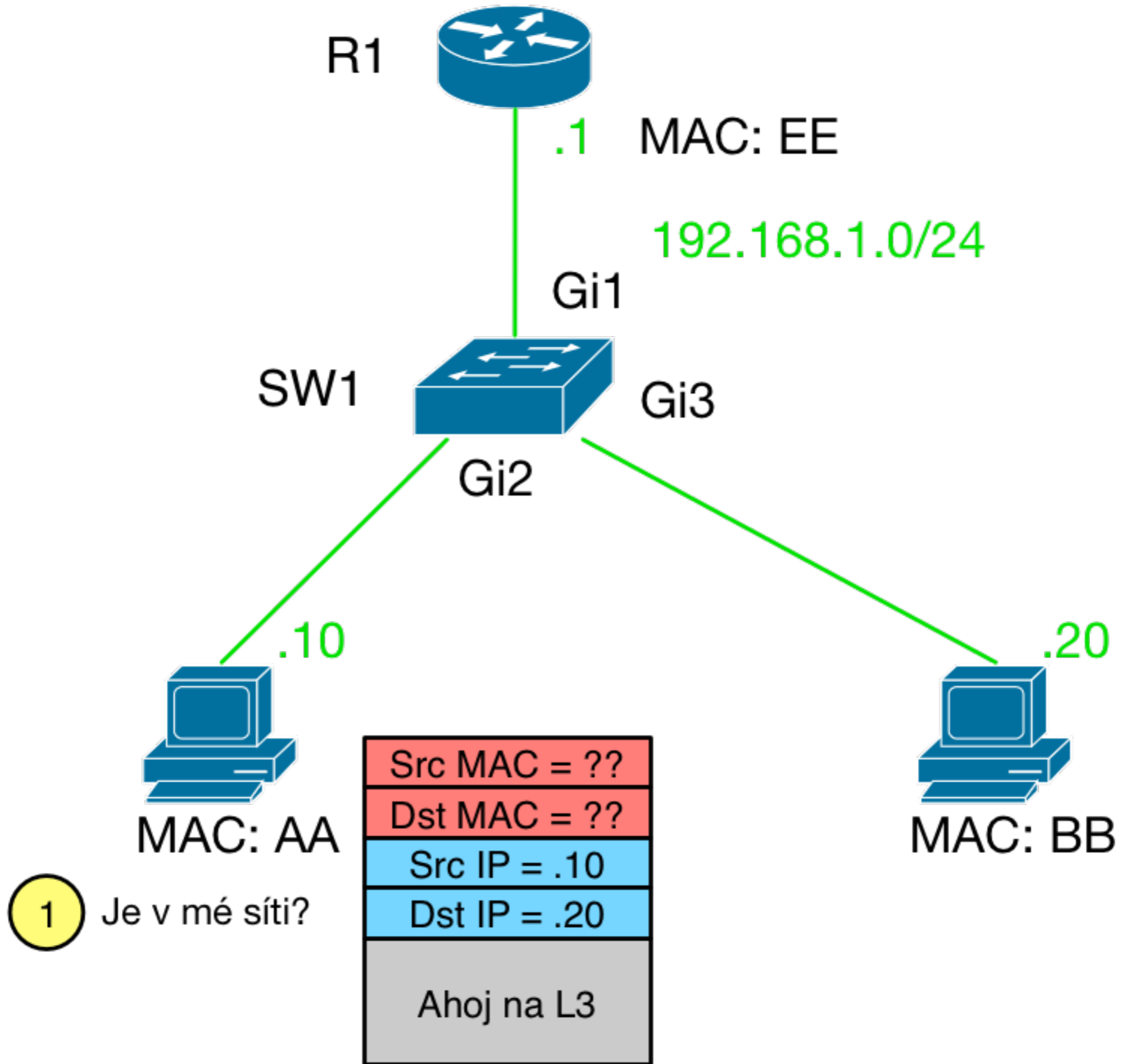

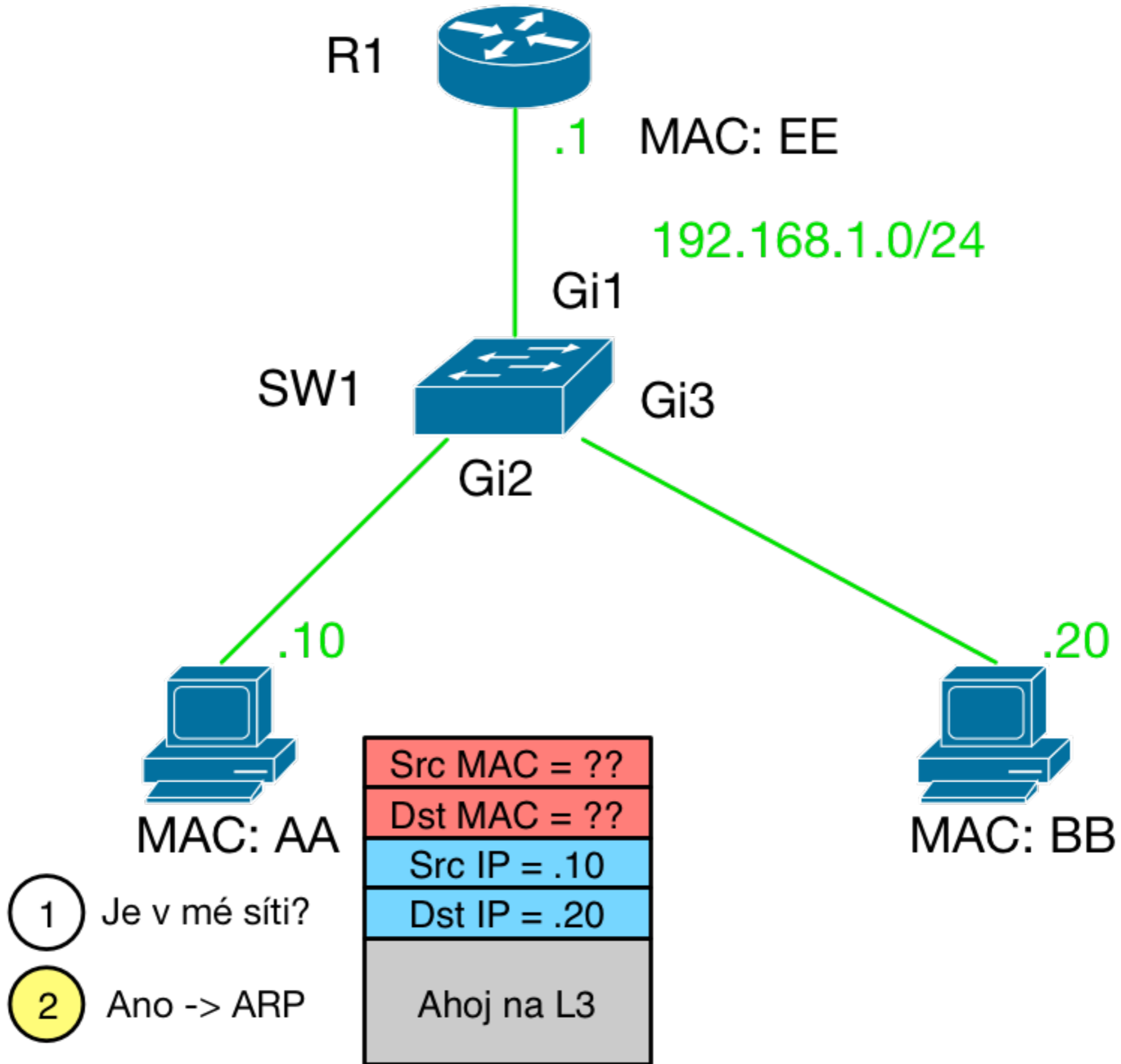

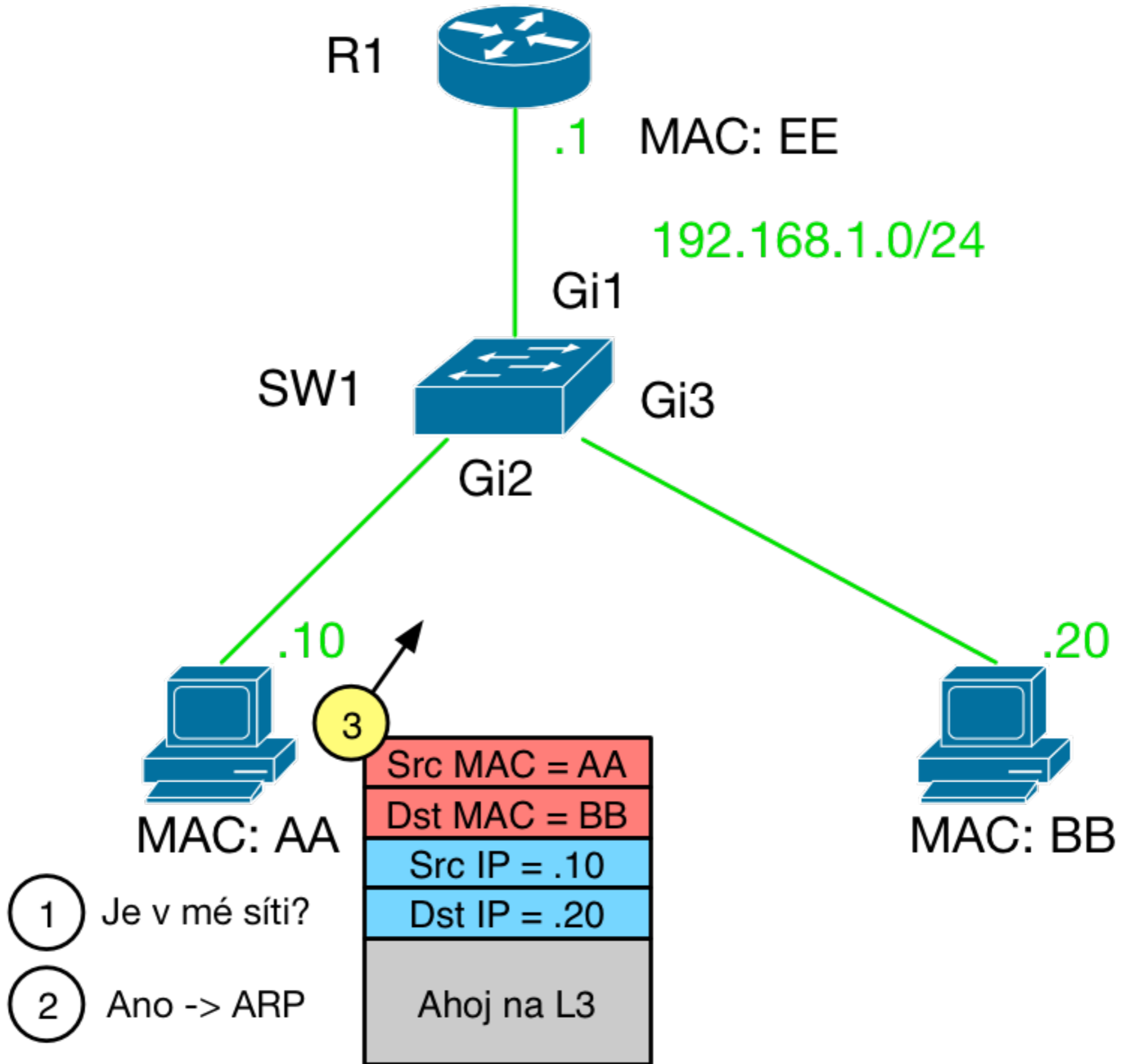

# Komunikace na L3 II.

Default gateway/route



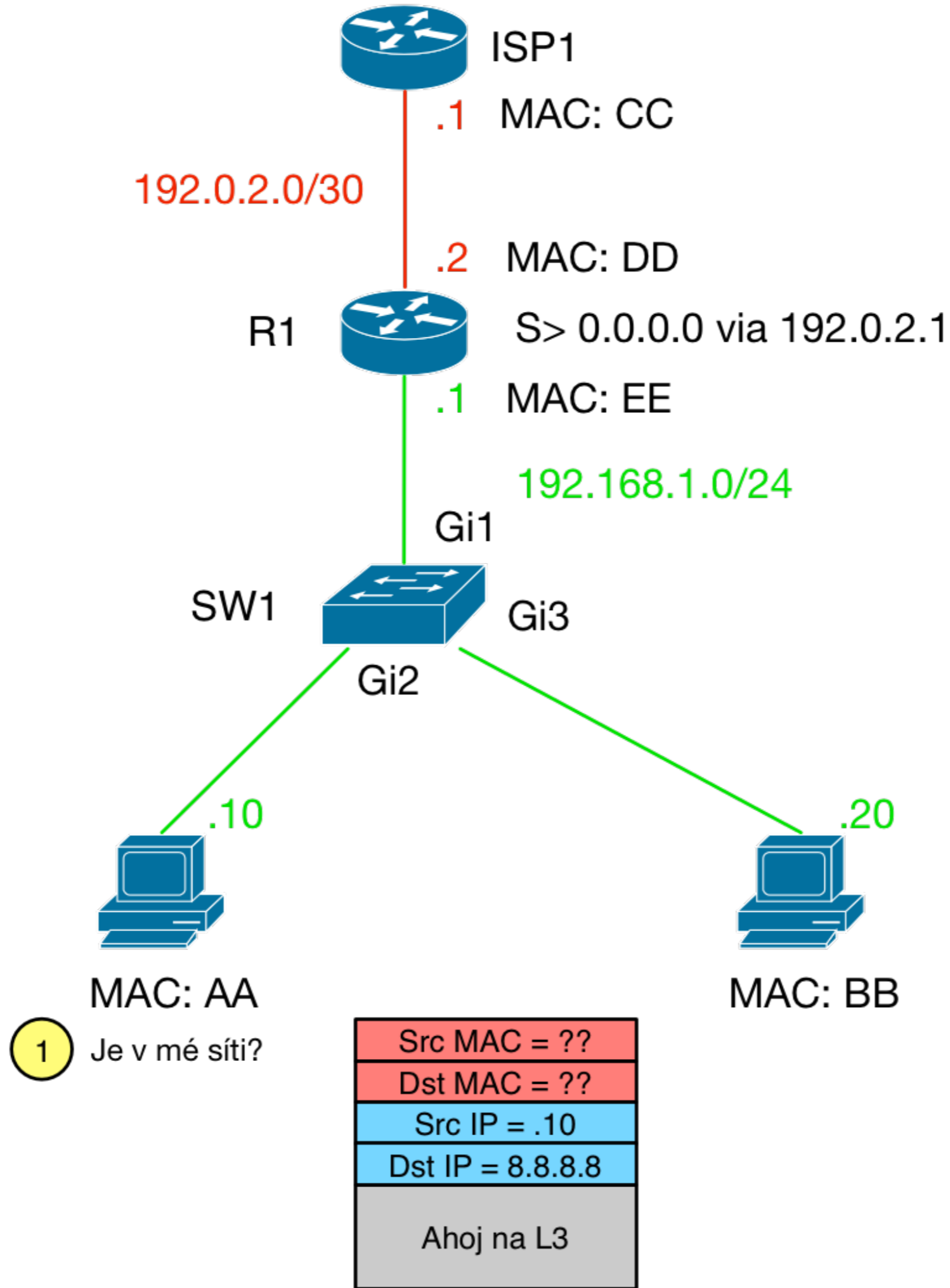

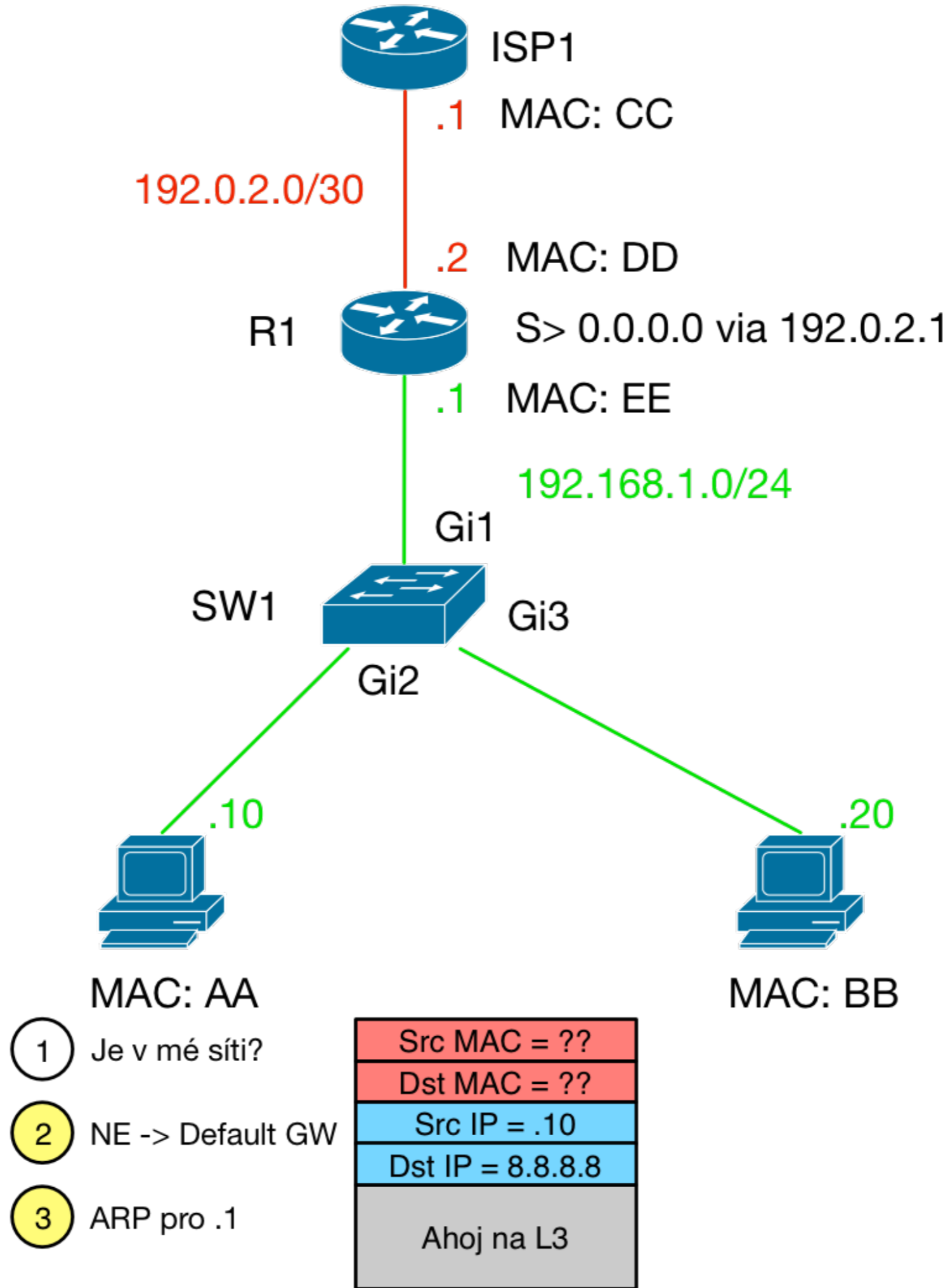

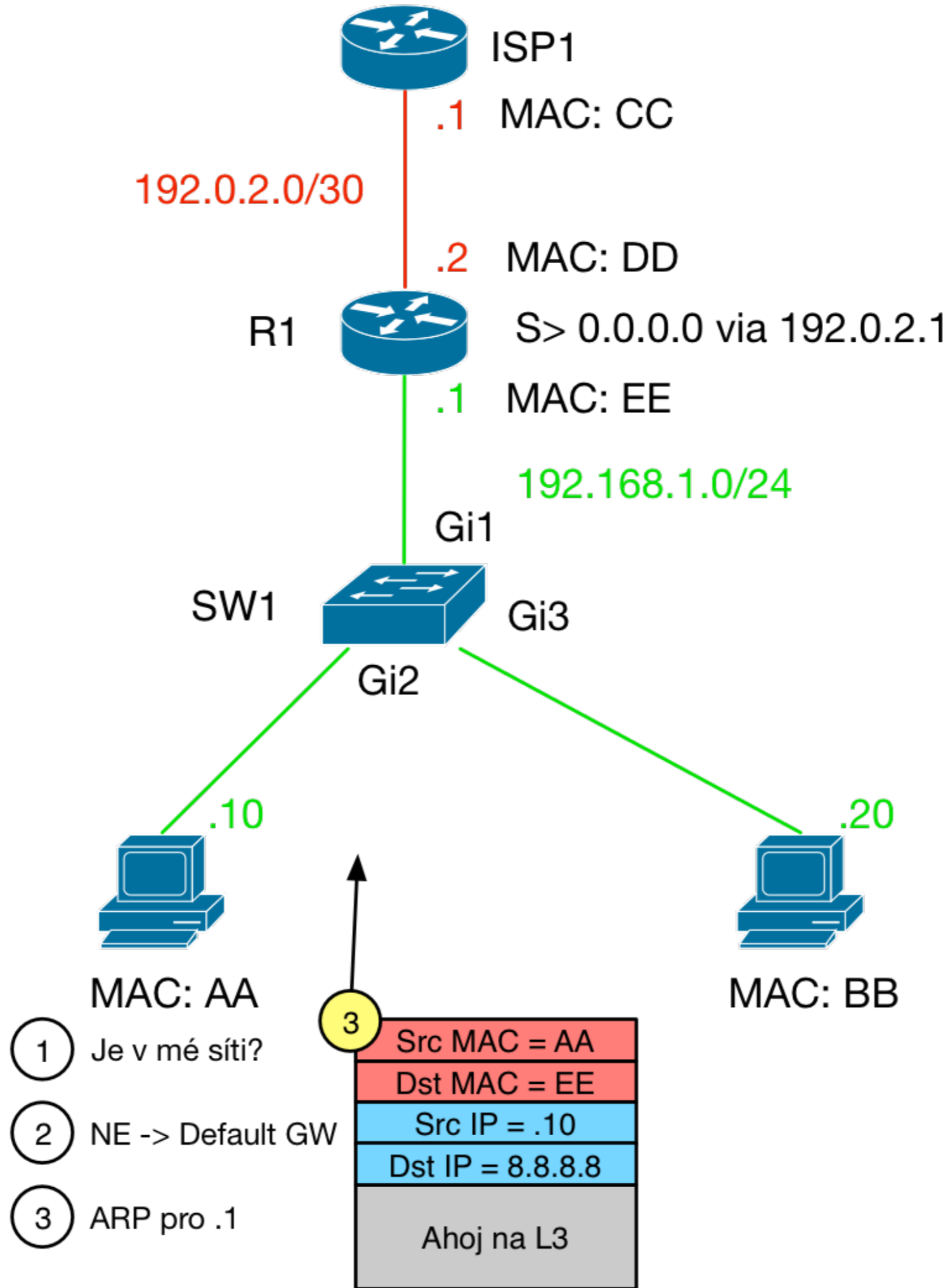

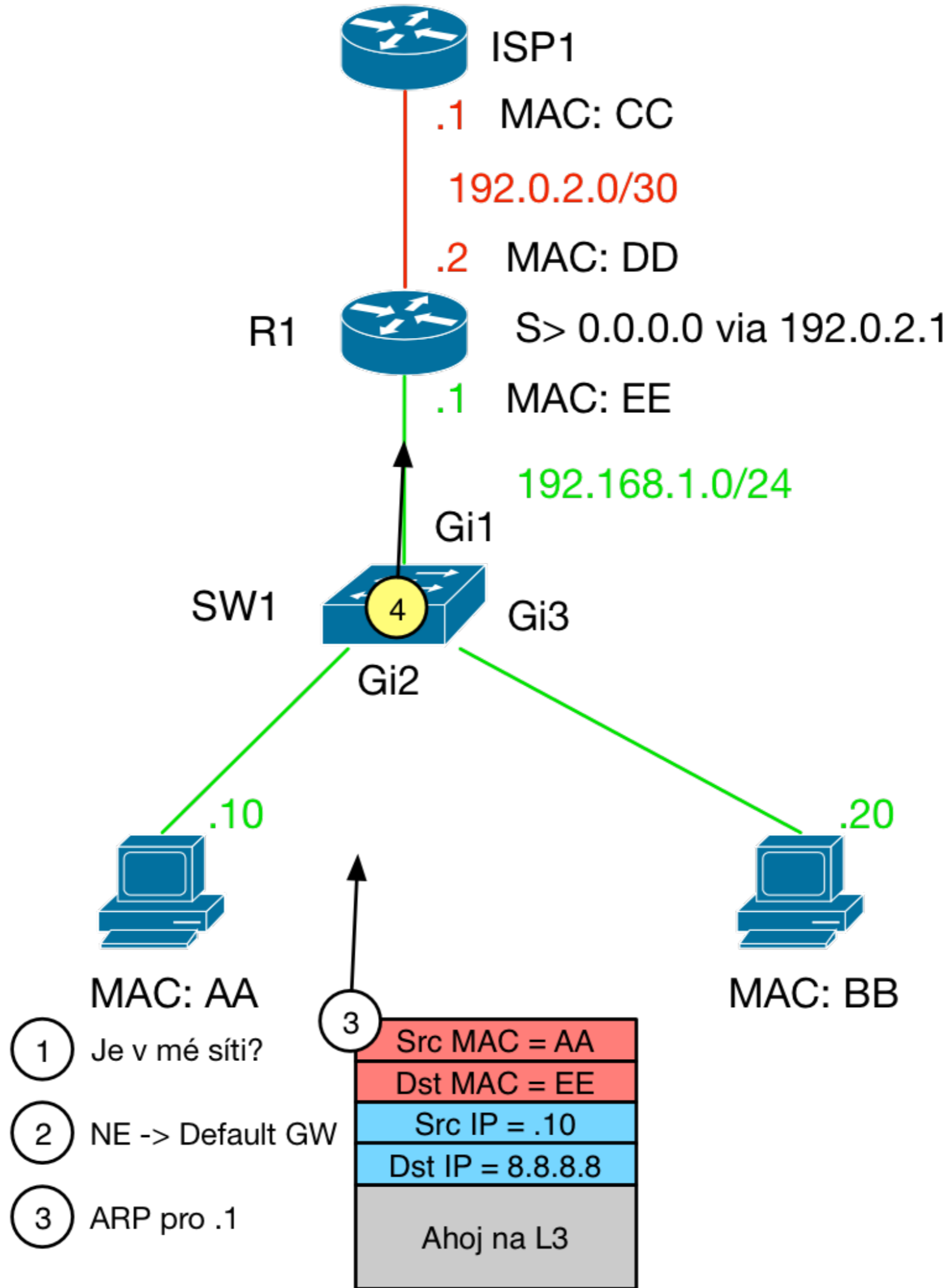

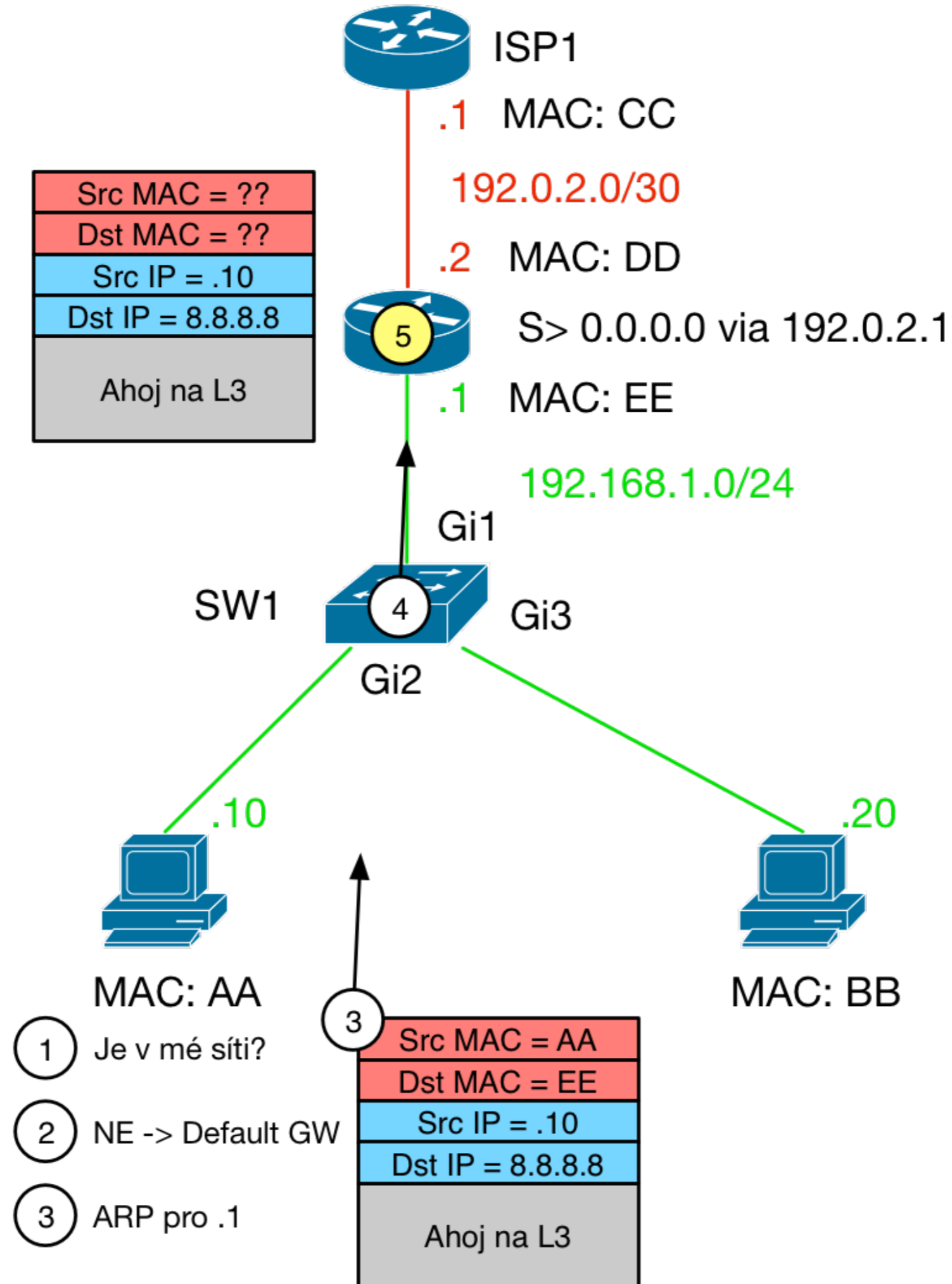

- 1 Je v mé síti?
- 2 NE -> Default GW
- 3 ARP pro .1

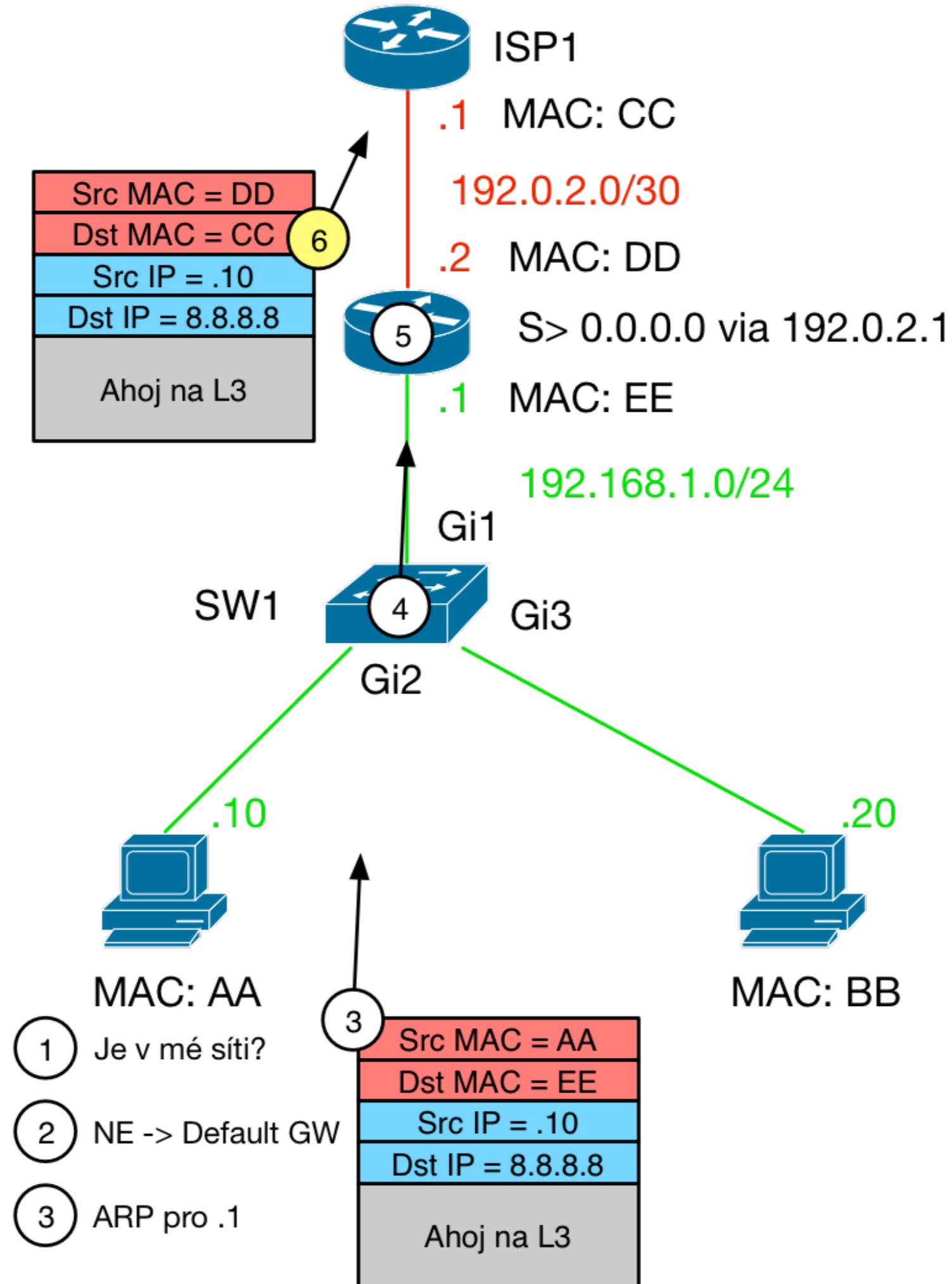

# Komunikace na L3 III.

Network Address Translation

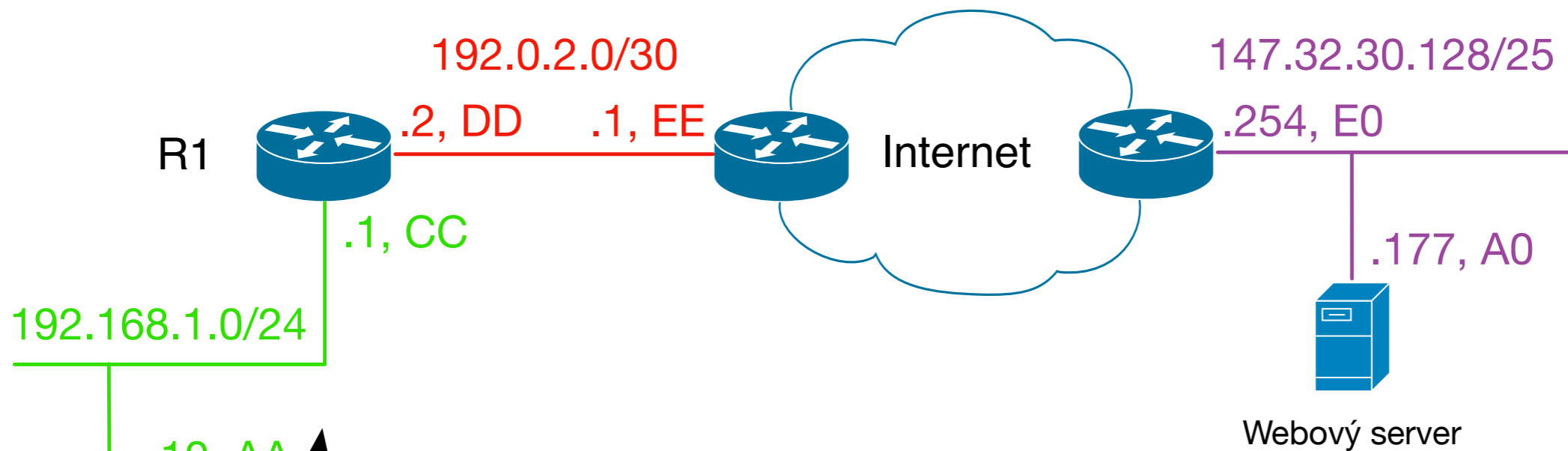

5	Src MAC = AA
	Dst MAC = CC
	Src IP = 192.168.1.10
	Dst IP = 147.32.30.177
	Src Port = 1234
	Dst Port = 80
	GET / HTTP/1.0 Host: silconhill.cz

- 1 http://silconhill.cz
- 2 DNS Query A silconhill.cz
- 3 DNS Reply 147.32.30.177
- 4 Je 147.32.30.177 v mé síti?  
-> Ne -> ARP Default GW .1



## R1 NAT Table

Src IP	Dst IP	Src Port	Dst Port	NAT Src IP	NAT Src Port

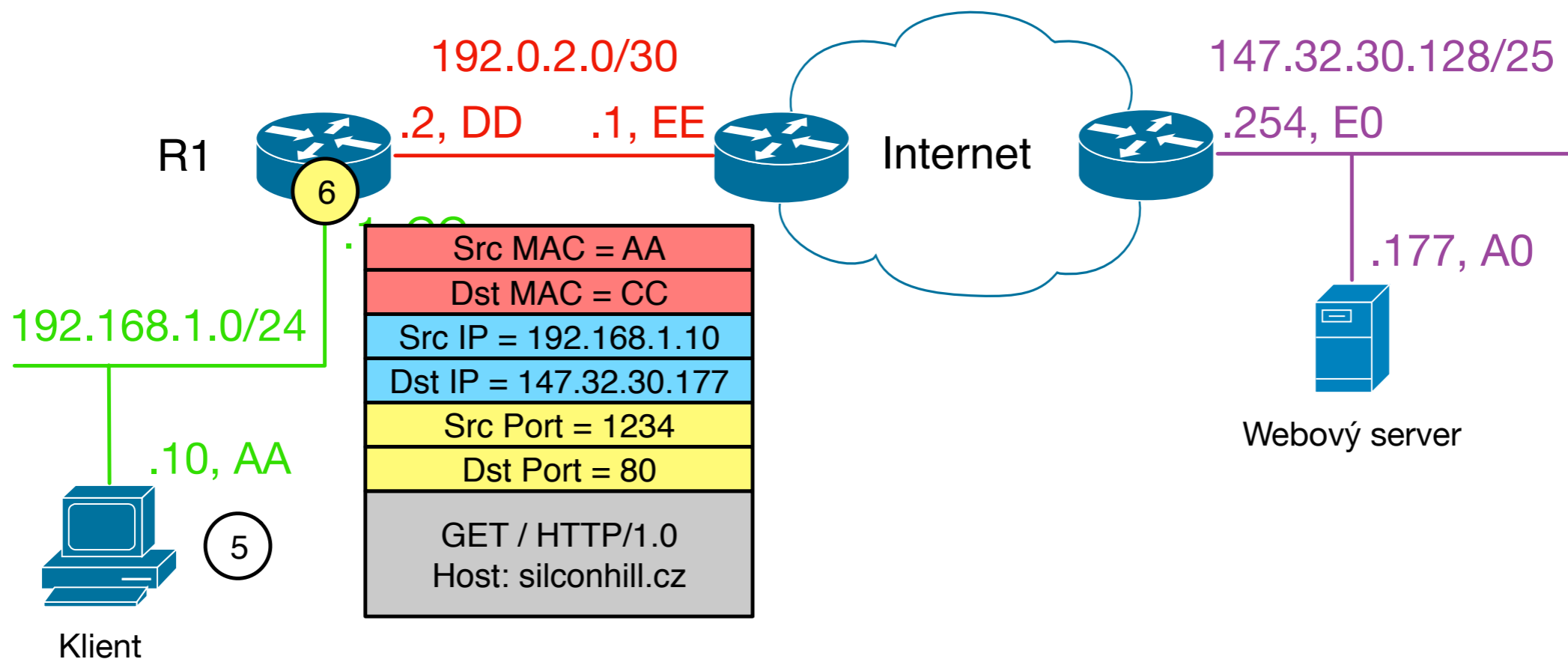

- 1 http://siliconhill.cz
- 2 DNS Query A siliconhill.cz
- 3 DNS Reply 147.32.30.177
- 4 Je 147.32.30.177 v mé síti?  
-> Ne -> ARP Default GW .1

## R1 NAT Table

Src IP	Dst IP	Src Port	Dst Port	NAT Src IP	NAT Src Port
192.168.1.10	147.32.30.177	1234	80	192.0.2.1	5768

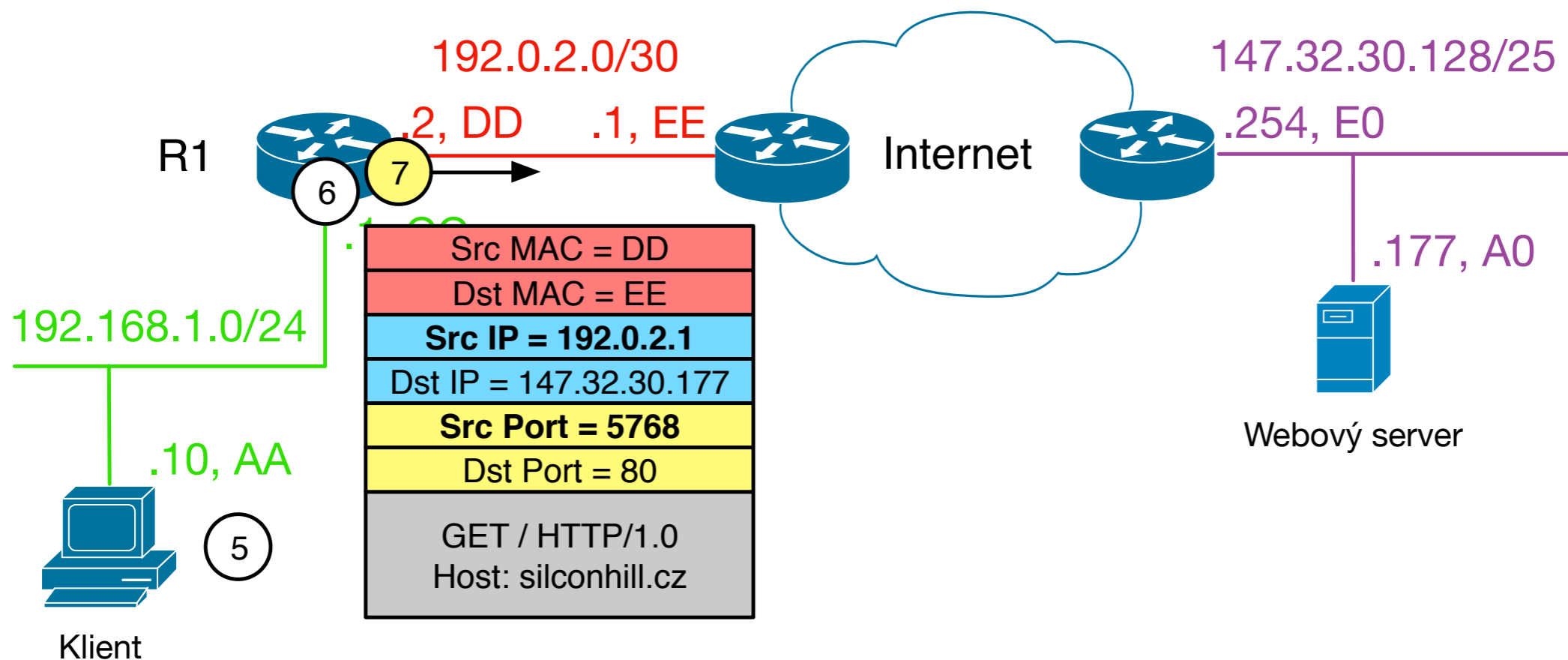

- 1 http://siliconhill.cz
- 2 DNS Query A siliconhill.cz
- 3 DNS Reply 147.32.30.177
- 4 Je 147.32.30.177 v mé síti?  
-> Ne -> ARP Default GW .1

## R1 NAT Table

Src IP	Dst IP	Src Port	Dst Port	NAT Src IP	NAT Src Port
192.168.1.10	147.32.30.177	1234	80	192.0.2.1	5768

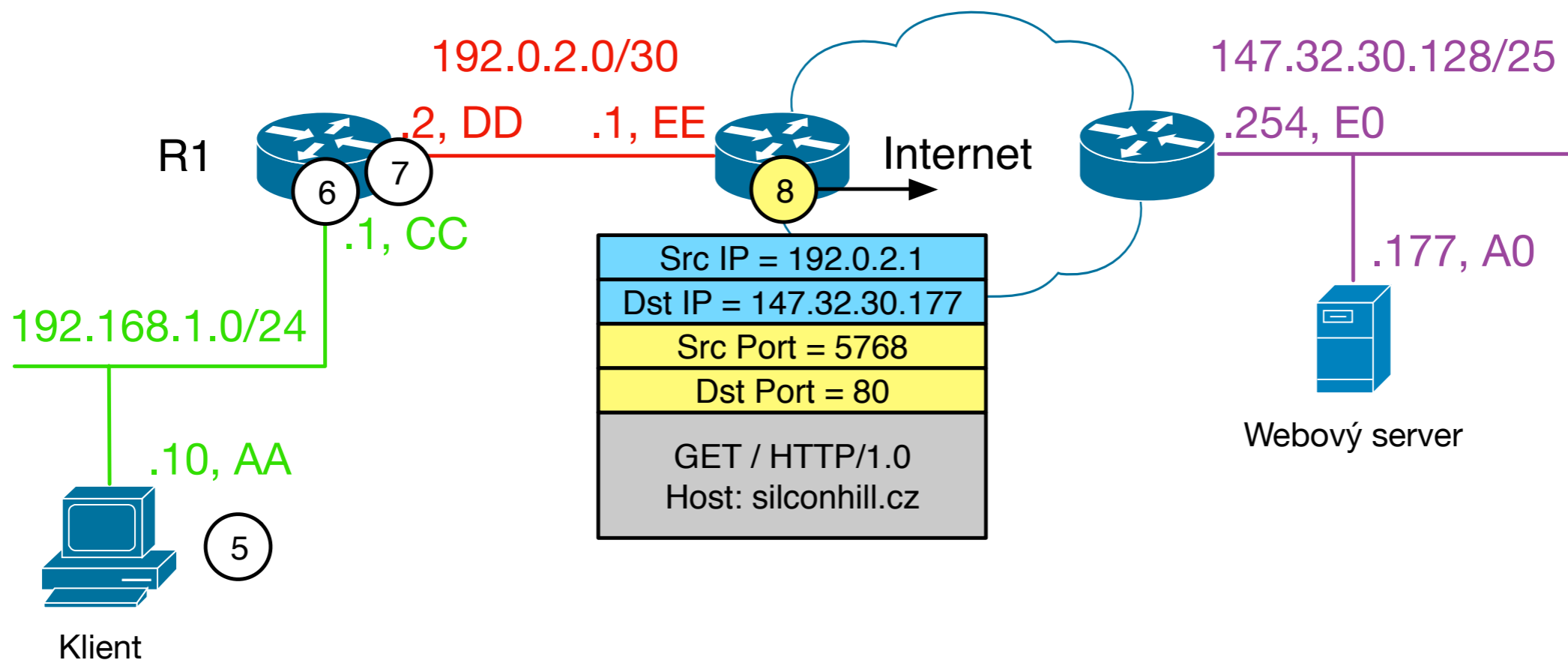

- 1 http://siliconhill.cz
- 2 DNS Query A siliconhill.cz
- 3 DNS Reply 147.32.30.177
- 4 Je 147.32.30.177 v mé síti?  
-> Ne -> ARP Default GW .1

## R1 NAT Table

Src IP	Dst IP	Src Port	Dst Port	NAT Src IP	NAT Src Port
192.168.1.10	147.32.30.177	1234	80	192.0.2.1	5768

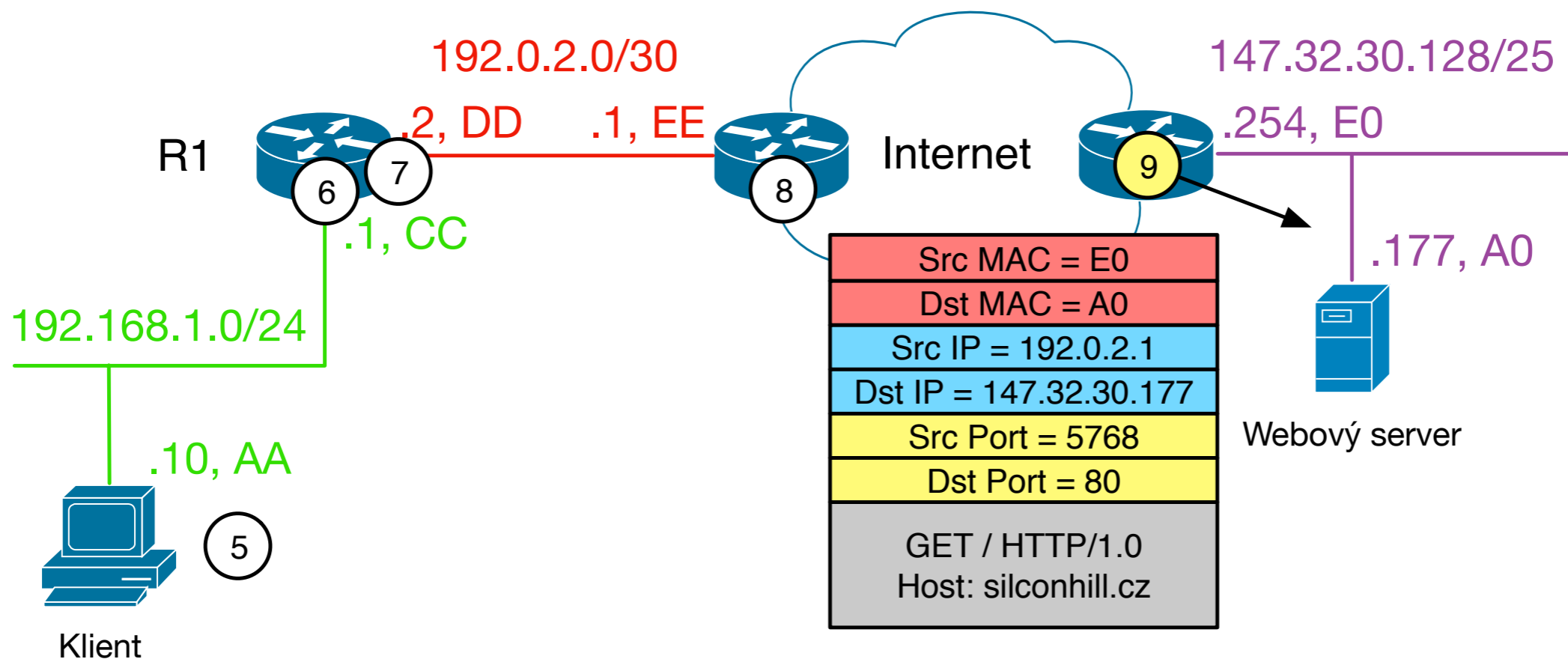

- 1 http://siliconhill.cz
- 2 DNS Query A siliconhill.cz
- 3 DNS Reply 147.32.30.177
- 4 Je 147.32.30.177 v mé síti?  
-> Ne -> ARP Default GW .1

## R1 NAT Table

Src IP	Dst IP	Src Port	Dst Port	NAT Src IP	NAT Src Port
192.168.1.10	147.32.30.177	1234	80	192.0.2.1	5768

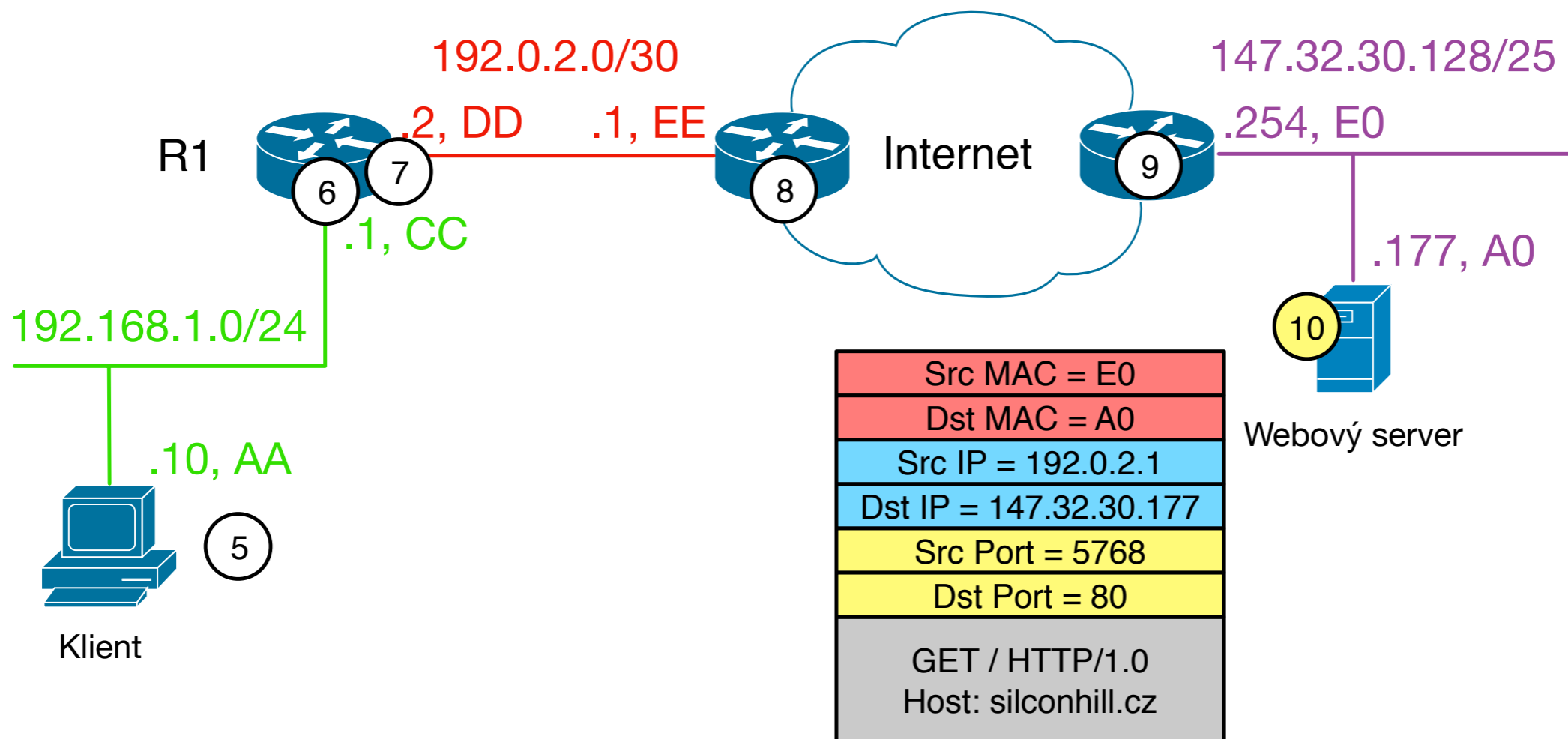

- 1 http://siliconhill.cz
- 2 DNS Query A siliconhill.cz
- 3 DNS Reply 147.32.30.177
- 4 Je 147.32.30.177 v mé síti?  
-> Ne -> ARP Default GW .1

## R1 NAT Table

Src IP	Dst IP	Src Port	Dst Port	NAT Src IP	NAT Src Port
192.168.1.10	147.32.30.177	1234	80	192.0.2.1	5768

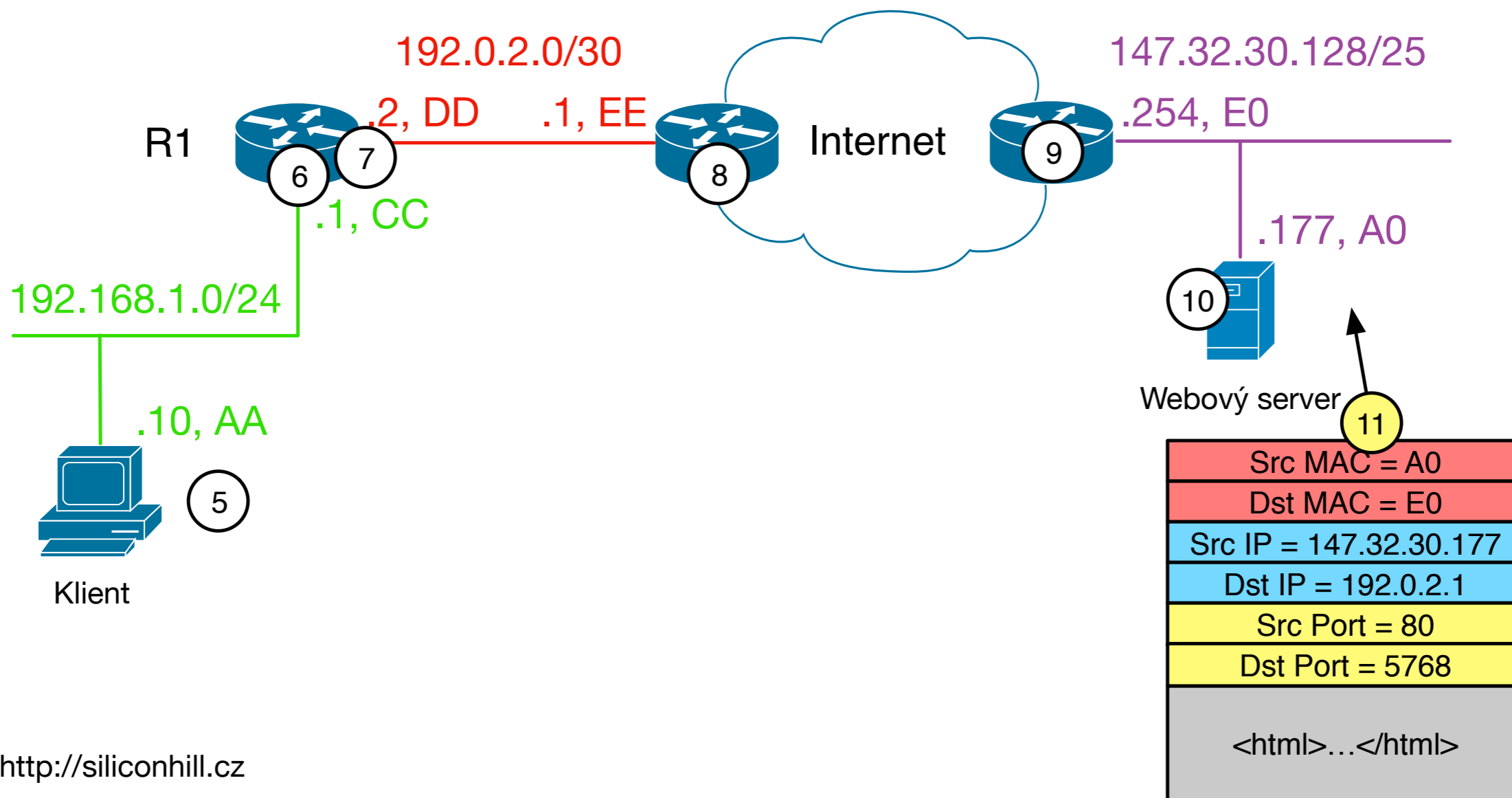

- 1 http://siliconhill.cz
- 2 DNS Query A siliconhill.cz
- 3 DNS Reply 147.32.30.177
- 4 Je 147.32.30.177 v mé síti?  
-> Ne -> ARP Default GW .1

## R1 NAT Table

Src IP	Dst IP	Src Port	Dst Port	NAT Src IP	NAT Src Port
192.168.1.10	147.32.30.177	1234	80	192.0.2.1	5768

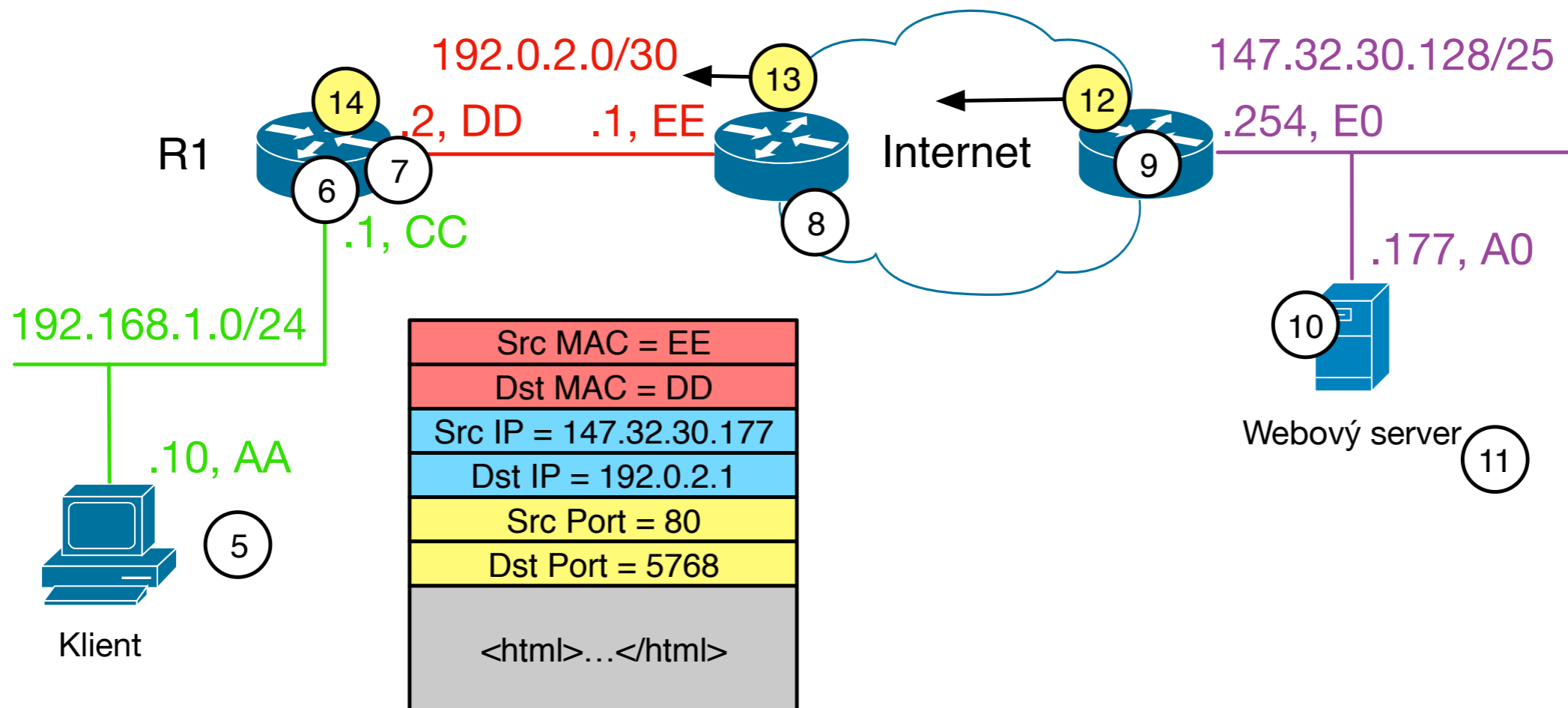

- 1 http://siliconhill.cz
- 2 DNS Query A siliconhill.cz
- 3 DNS Reply 147.32.30.177
- 4 Je 147.32.30.177 v mé síti?  
-> Ne -> ARP Default GW .1

## R1 NAT Table

Src IP	Dst IP	Src Port	Dst Port	NAT Src IP	NAT Src Port
192.168.1.10	147.32.30.177	1234	80	192.0.2.1	5768

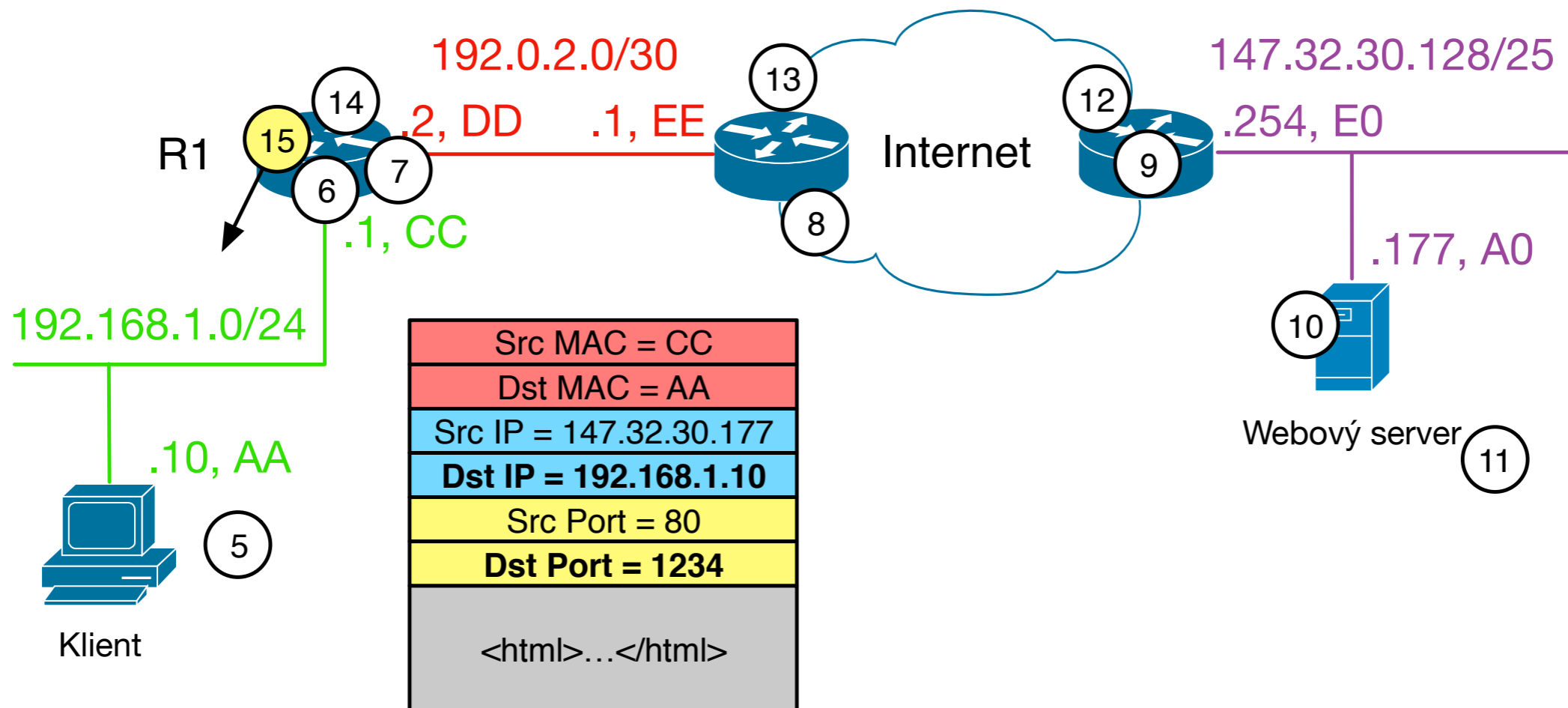

- 1 http://siliconhill.cz
- 2 DNS Query A siliconhill.cz
- 3 DNS Reply 147.32.30.177
- 4 Je 147.32.30.177 v mé síti?  
-> Ne -> ARP Default GW .1



## R1 NAT Table

Src IP	Dst IP	Src Port	Dst Port	NAT Src IP	NAT Src Port
192.168.1.10	147.32.30.177	1234	80	192.0.2.1	5768

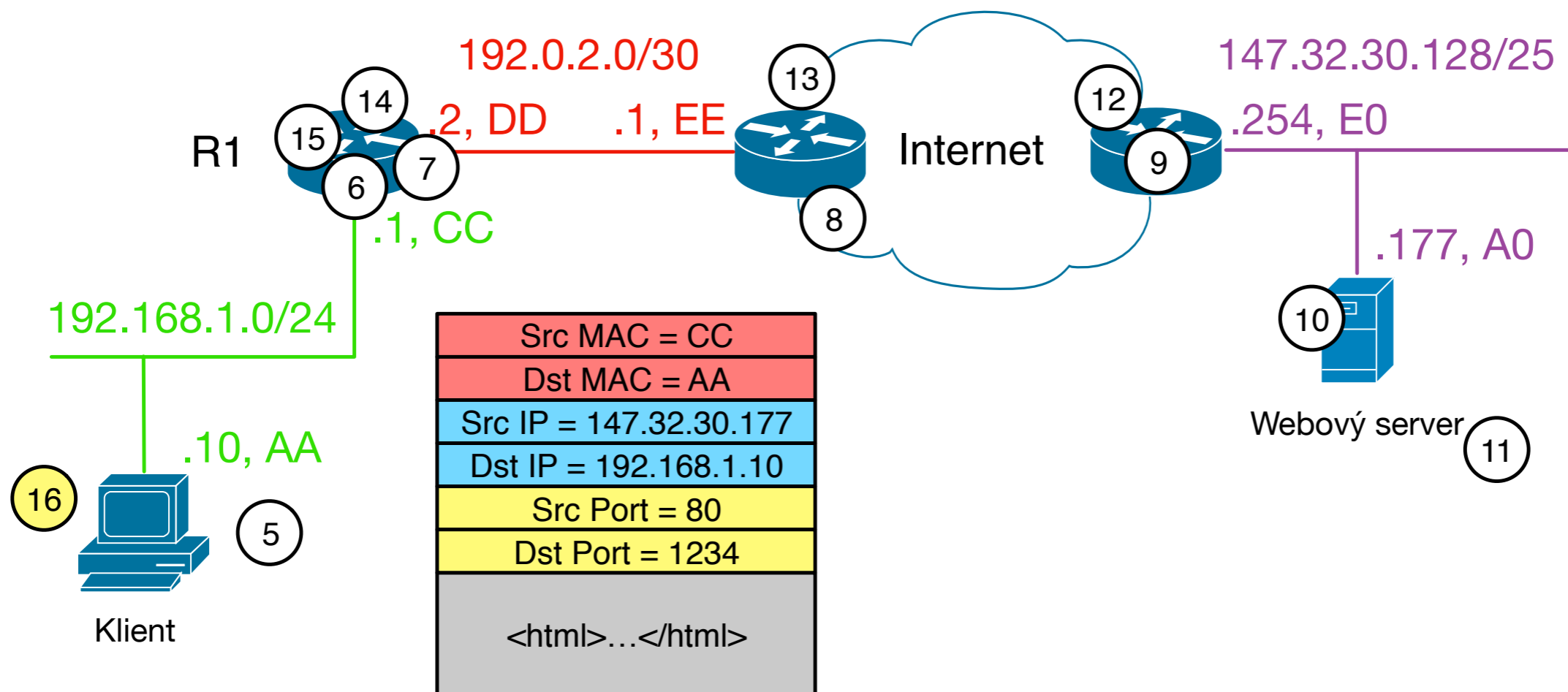

- 1 http://siliconhill.cz
- 2 DNS Query A siliconhill.cz
- 3 DNS Reply 147.32.30.177
- 4 Je 147.32.30.177 v mé síti?  
-> Ne -> ARP Default GW .1

# Switches

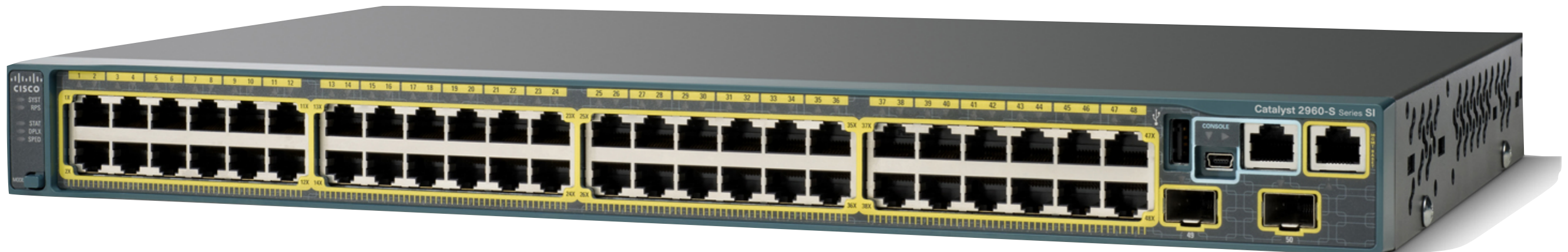

# Router



# Modulární L3 Switch



# Co jsme neprobrali

- VLAN, STP, Port channel, VPC
- SNMP, Management, Dohled
- DNAT, SNAT, NAT 1:1
- Routovací protokoly, Statické routy
- PBR, VRF, QoS, CoPP
- VPN – Site to site + Remote access
- ...

